

AKAI SERVICE MANUAL

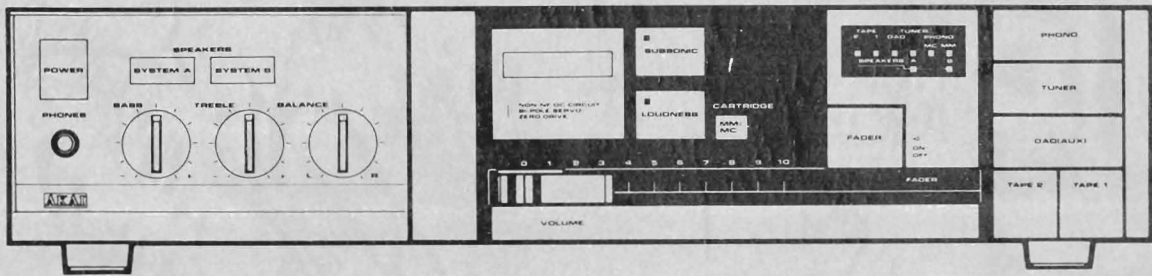

STEREO INTEGRATED AMPLIFIER

MODEL **AM-U5**

ABBREVIATIONS FOR SERVICE MANUAL MODEL AM-U5

ABBREVIATION	EXPLANATION
AC	Alternating Current
RL	ReLay
DC	Direct Current
EQ	EQualizer
SW	SWitch
MM	Moving Magnet (Cartridge)
MC	Moving Coil (Cartridge)
GND	GrouND
INV	INVerter
DET	DETeCTOR

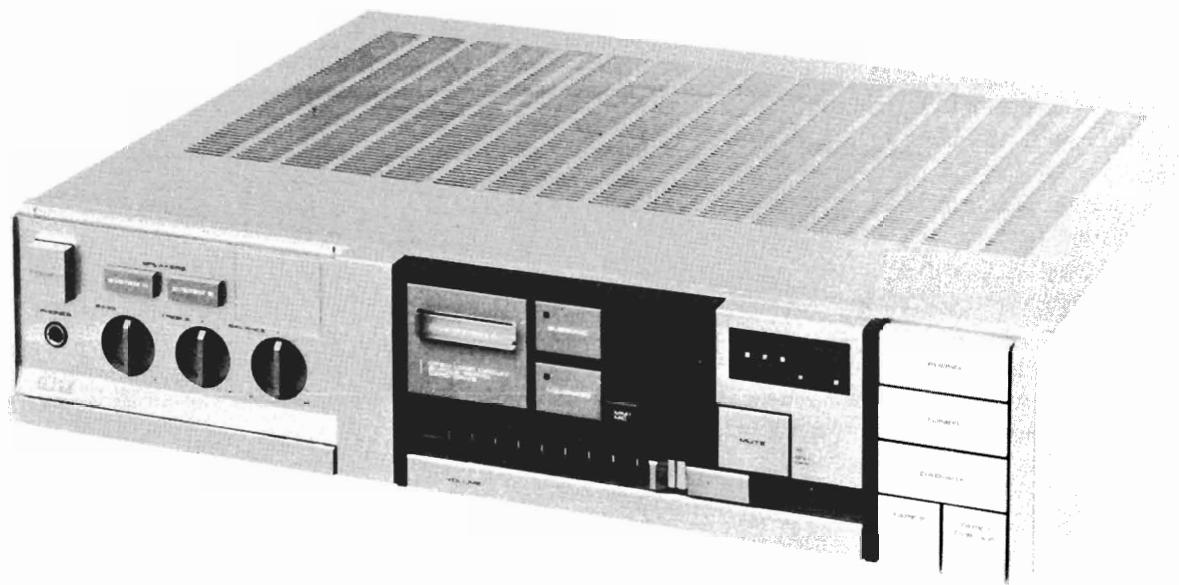

STEREO INTEGRATED AMPLIFIER

MODEL AM-U5

SECTION 1	SERVICE MANUAL	3
SECTION 2	PARTS LIST	17
SECTION 3	SCHEMATIC DIAGRAM	25

SAFETY INSTRUCTIONS

SAFETY CHECK AFTER SERVICING

Confirm the specified insulation resistance between power cord plug prongs and externally exposed parts of the set is greater than 10 Mohms, but for equipment with external antenna terminals (tuner, receiver, etc.) and is intended for **C** or **A**, specified insulation resistance should be more than 2.2 Mohms (ground terminals, microphone jacks, headphone jacks, line-in-out jacks etc.)

PRECAUTIONS DURING SERVICING

1. Parts identified by the Δ symbol parts are critical for safety.
Replace only with parts number specified.
2. In addition to safety, other parts and assemblies are specified for conformance with such regulations as those applying to spurious radiation. These must also be replaced only with specified replacements.
Examples: RF converters, tuner units, antenna selector switches, RF cables, noise blocking capacitors, noise blocking filters, etc.
3. Use specified internal wiring. Note especially:
 - 1) Wires covered with PVC tubing
 - 2) Double insulated wires
 - 3) High voltage leads
4. Use specified insulating materials for hazardous live parts. Note especially:
 - 1) Insulation Tape
 - 2) PVC tubing
 - 3) Spacers (Insulating Barriers)
 - 4) Insulation sheets for transistors
 - 5) Plastic screws for fixing microswitch (especially in turntable)
5. When replacing AC primary side components (transformers, power cords, noise blocking capacitors, etc.), wrap ends of wires securely about the terminals before soldering.

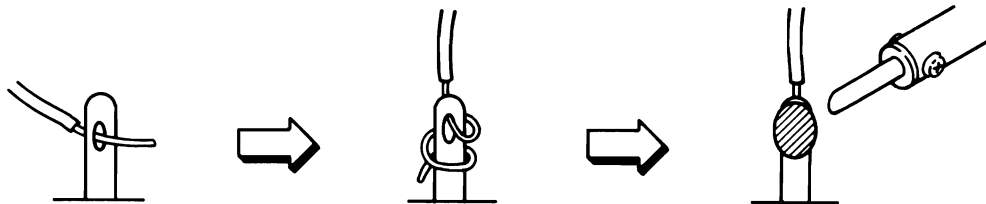

6. Observe that wires do not contact heat producing parts (heatsinks, oxide metal film resistors, fusible resistors, etc.).
7. Check that replaced wires do not contact sharp edged or pointed parts.
8. Also check areas surrounding repaired locations.
9. Use care that foreign objects (screws, solder droplets, etc.) do not remain inside the set.
10. Voltage Conversion
Models for Canada, USA, Europe, UK and Australia are not equipped with this facility. Each machine is preset at the factory according to its destination, but some machines can be set to 110V, 120V, 220V or 240V as required. If your machine's voltage can be converted:
 - 1) Disconnect the power cord from the power supply.
 - 2) Turn the VOLTAGE SELECTOR located on the rear panel with a screwdriver until the correct voltage is indicated.

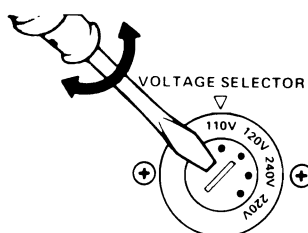

SECTION 1

SERVICE MANUAL

TABLE OF CONTENTS

I.	SPECIFICATIONS	4
II.	DISMANTLING OF UNIT	5
III.	CONTROLS	6
IV.	PRINCIPAL PARTS LOCATION	7
V.	CIRCUIT OPERATION	8
	5-1 ZERO DRIVE	8
	5-2 OVERCURRENT DETECTING CIRCUIT	8
VI.	ADJUSTMENTS	9
	6-1 IDLING CURRENT ADJUSTMENT	9
	6-2 EQ AMP DC BALANCE ADJUSTMENT	9
VII.	CLASSIFICATION OF VARIOUS P.C BOARD	10
	7-1 P.C BOARD TITLES AND IDENTIFICATION NUMBERS	10
	7-2 COMPOSITION OF VARIOUS P.C BOARDS	11

For basic adjustments, measuring methods, and operating principles, refer to GENERAL TECHNICAL MANUAL.

I. SPECIFICATIONS

POWER AMPLIFIER SECTION

RATED POWER OUTPUT (2 channels Driven) 20 to 20,000 Hz 1 kHz	8 ohms 60W x 2/0.5% 65W x 2/0.5%	4 ohms 60W x 2/0.5% 73W x 2/0.7%
SIGNAL TO NOISE RATIO (IHF-A) PHONO AUX	MM: 88 dB MC: 65 dB 100 dB	
RESIDUAL NOISE (8 ohms)	0.2 mV	
CHANNEL SEPARATION (IHF, 1 kHz)	65 dB (PHONO)	
DAMPING FACTOR (1 kHz, 8 ohms)	30	
OUTPUT IMPEDANCE SPEAKERS	4 to 16 ohms (A or B) 8 to 16 ohms (A and B)	

PRE AMPLIFIER SECTION

INPUT SENSITIVITY/IMPEDANCE PHONO AUX TUNER TAPE	MM: 2.5 mV/47 kohms MC : 0.25 mV/100 ohms 150 mV/47 kohms 150 mV/47 kohms 150 mV/47 kohms
OUTPUT LEVEL/IMPEDANCE TAPE REC	150 mV/1 kohm
FREQUENCY RESPONSE PHONO (RIAA Deviation) TUNER/AUX/TAPE	20 Hz to 20 kHz ± 0.2 dB 5 Hz to 100 kHz -2 dB
TONE CONTROL BASS TREBLE	± 8 dB/100 Hz ± 8 dB/10 kHz
LOUDNESS CONTROL (Volume set at -30 dB position)	$+10$ dB/100 Hz, $+6$ dB/10 kHz
SUBSONIC FILTER	-3 dB/oct at 18 Hz
PHONO MAX. INPUT LEVEL (1 kHz)	MM: 250 mV MC : 25 mV
POWER REQUIREMENT	120V, 60 Hz for USA and Canada 220V, 50 Hz for Europe except UK 240V, 50 Hz for UK and Australia 110V/120V/220V/240V, 50/60 Hz switchable for other countries.
POWER CONSUMPTION	300W (U), 320W (A), 370VA (C), 250W (E), 500W (B,S)
DIMENSIONS	440(W) x 105(H) x 365(D) mm (17.3 x 4.1 x 14.4 inches)
WEIGHT	8.5 kg (18.7 lbs)

For improvement purposes, specifications and design are subject to change without notice.

II. DISMANTLING OF UNIT

In case of trouble, etc. necessitating dismantling, please dismantle in the order shown in the photographs. Reassemble in reverse order.

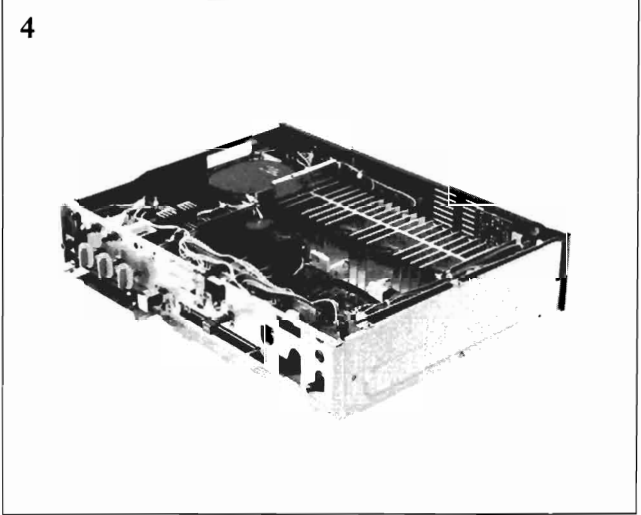
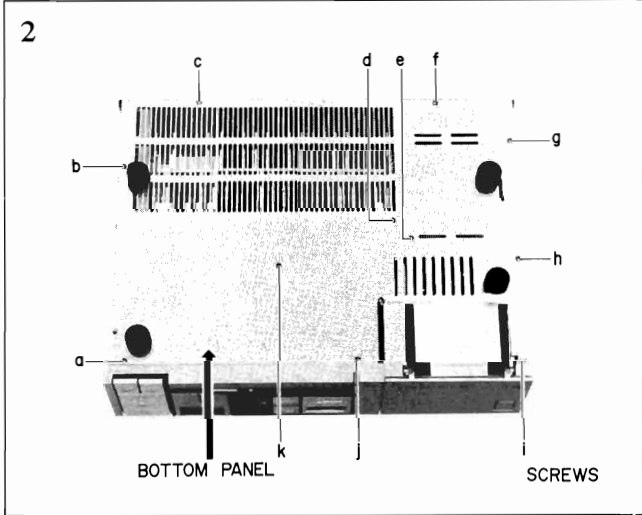
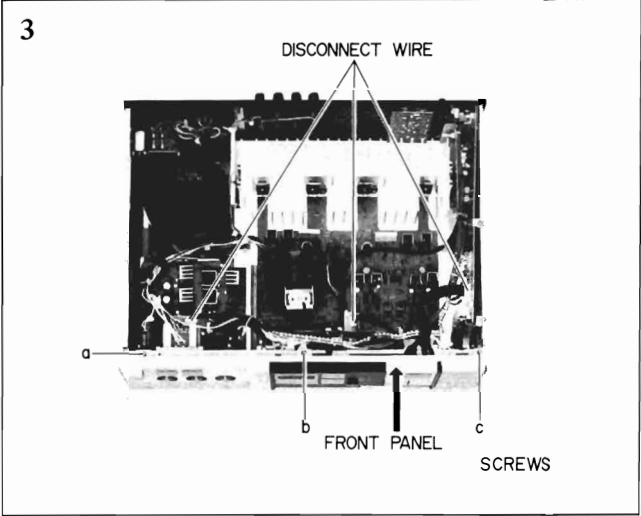
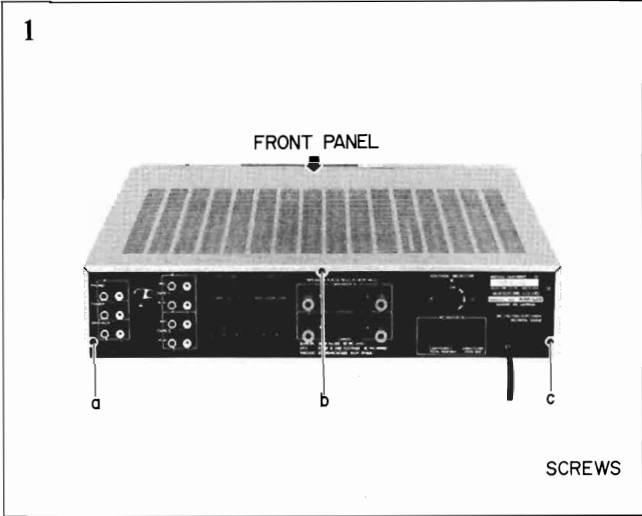

III. CONTROLS

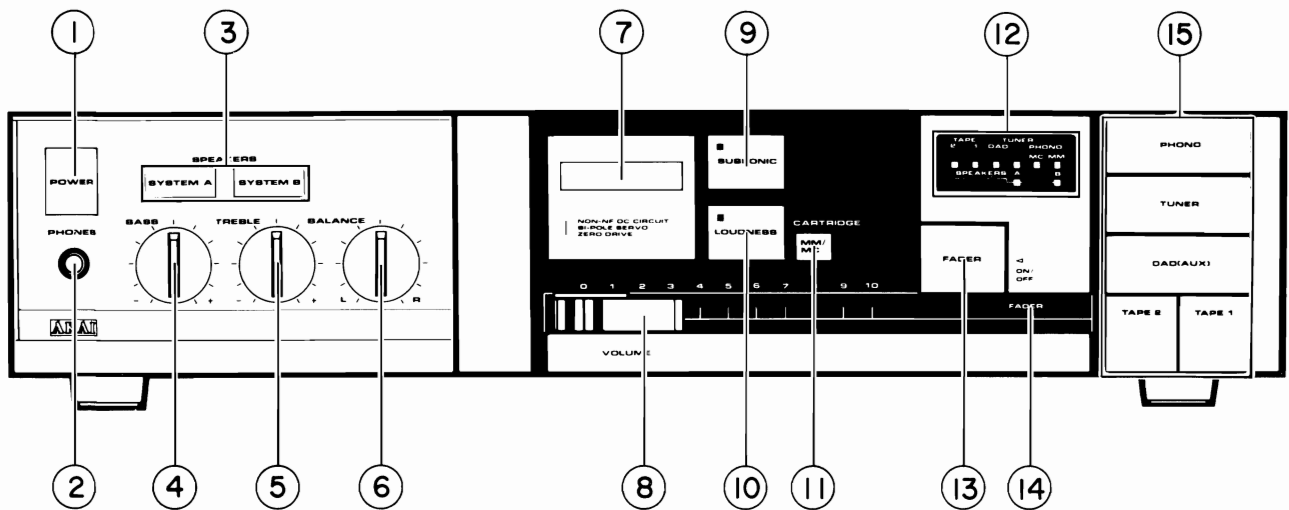

Fig. 3-1 Front View

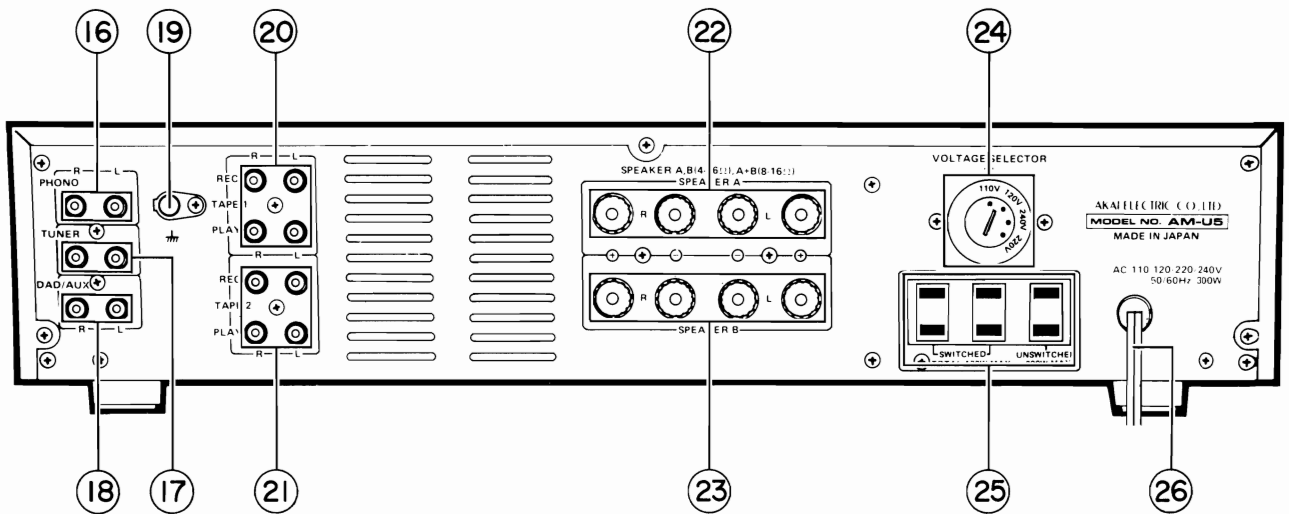

Fig. 3-2 Rear View

- | | |
|--|---|
| <ol style="list-style-type: none"> 1. POWER SWITCH 2. PHONES JACK 3. SPEAKER SELECTORS (A and B) 4. BASS CONTROL 5. TREBLE CONTROL 6. BALANCE CONTROL 7. LINE STRAIGHT SWITCH with INDICATOR 8. VOLUME CONTROL 9. SUBSONIC FILTER SWITCH with INDICATOR 10. LOUDNESS SWITCH with INDICATOR 11. CARTRIDGE SELECTOR (MM ■ /MC ■) 12. INPUT, CARTRIDGE and SPEAKER INDICATORS 13. FADER BUTTON 14. FADER INDICATOR | <ol style="list-style-type: none"> 15. INPUT SOURCE SELECTORS
(PHONO, TUNER, DAD/AUX, TAPE 1 and 2) 16. PHONO JACKS 17. TUNER JACKS 18. DAD/AUX JACKS 19. GROUND TERMINAL 20. TAPE 1 REC/PLAY JACKS 21. TAPE 2 REC/PLAY JACKS 22. SPEAKER A TERMINALS (Left and Right) 23. SPEAKER B TERMINALS (Left and Right) 24. VOLTAGE SELECTOR (□ model only) 25. AC OUTLETS (not on some models) 26. AC POWER CORD |
|--|---|

IV. PRINCIPAL PARTS LOCATION

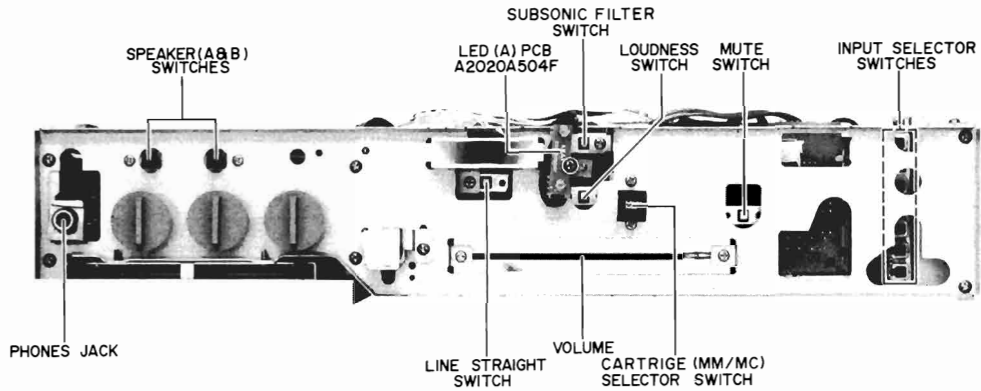

Fig. 4-1 Front View

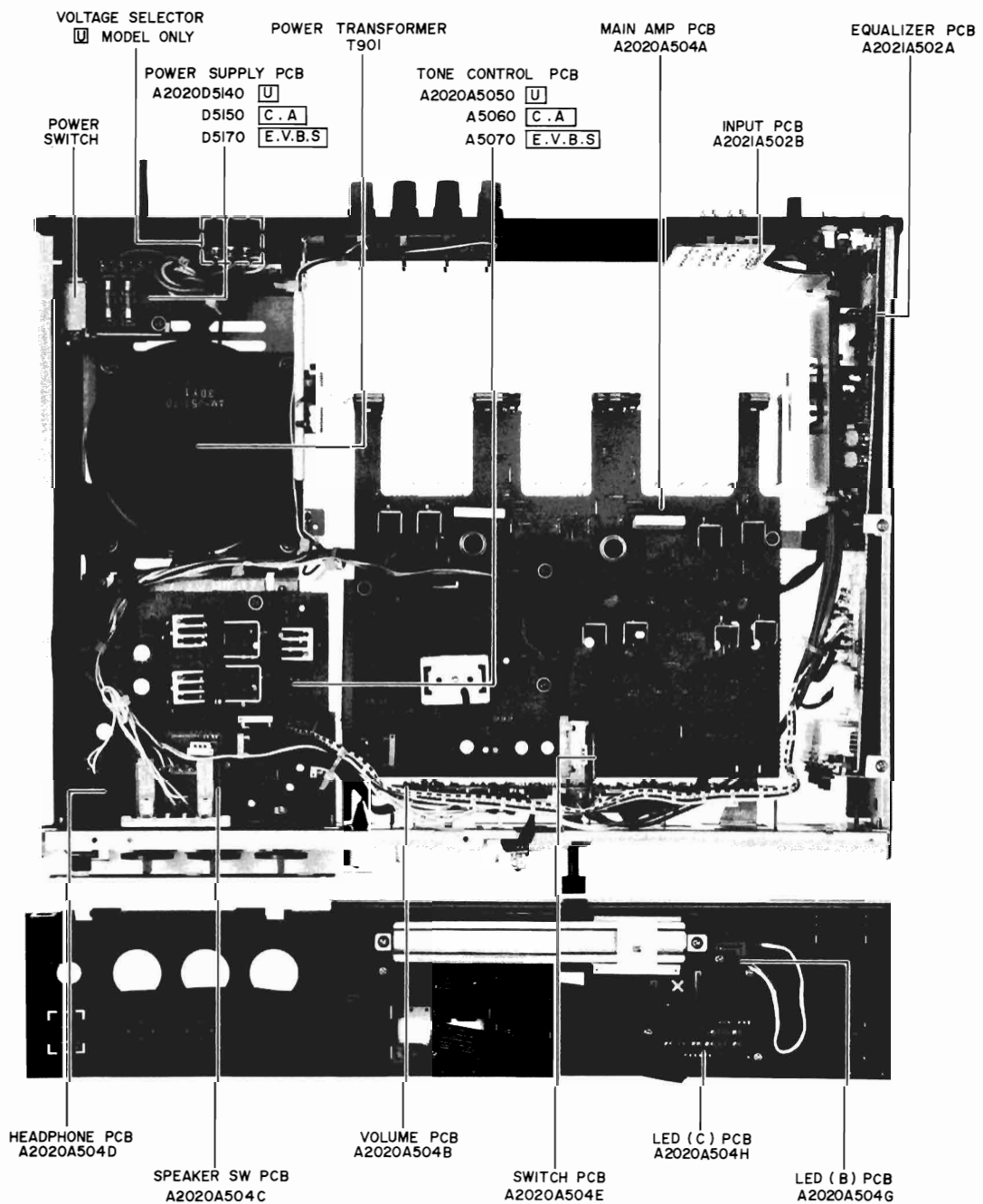

Fig. 4-2 Top View

V. CIRCUIT OPERATION

5-1 ZERO DRIVE (Refer to Fig. 5-1 & 5-2)

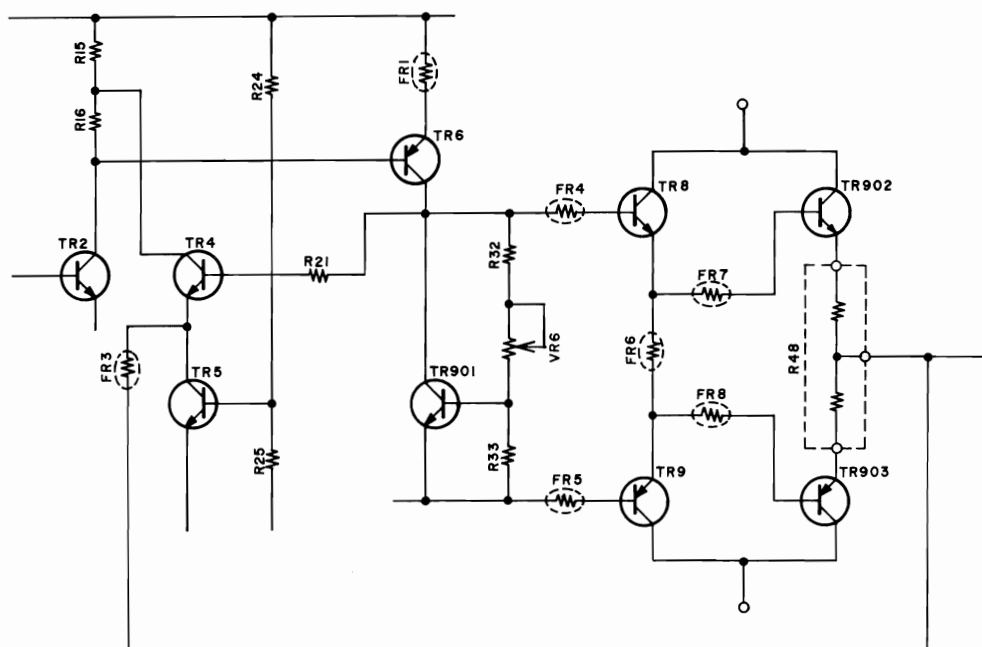

Fig. 5-1

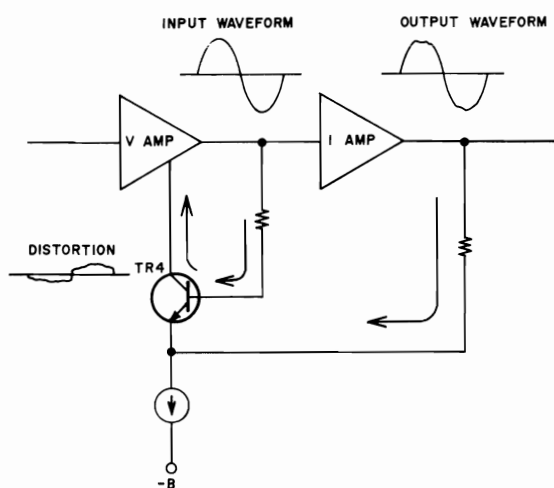

Fig. 5-2

This is intended to reduce distortions in the current amplifier stage. Voltage differences (distortion components) between the current amplifier stage (I Amp) input (TR8) and the main amp output (R48) when signals have been input, are detected with TR4, and signals will be applied to the voltage amplifier stage loads (R15 and R16) in a manner to cancel off the distortion components detected.

5-2 OVERCURRENT DETECTING CIRCUIT (Refer to Fig. 5-3)

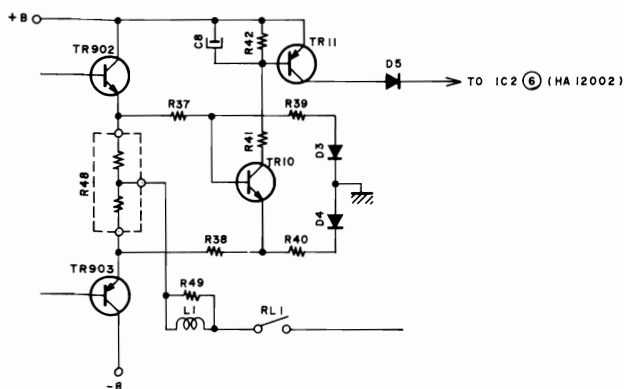

Fig. 5-3

Relay (RL1) is turned off for the protection of transistors against destruction and internal temperature rises, in the event that the load is shorted or the load impedance has dropped, causing an excessive current to flow. The voltage drop across R48 upon the flowing of an overcurrent turns TR10 on. Then, the TR11 base will be drawn to the ground potential, turning TR11 on. This draws the TR11 collector toward +B, and will activate the IC2 (HA12002) overcurrent detection, turning off relay (RL1). In this case, the relay (RL1) will not be reset until after the power switch has been pushed off at least once.

VI. ADJUSTMENT

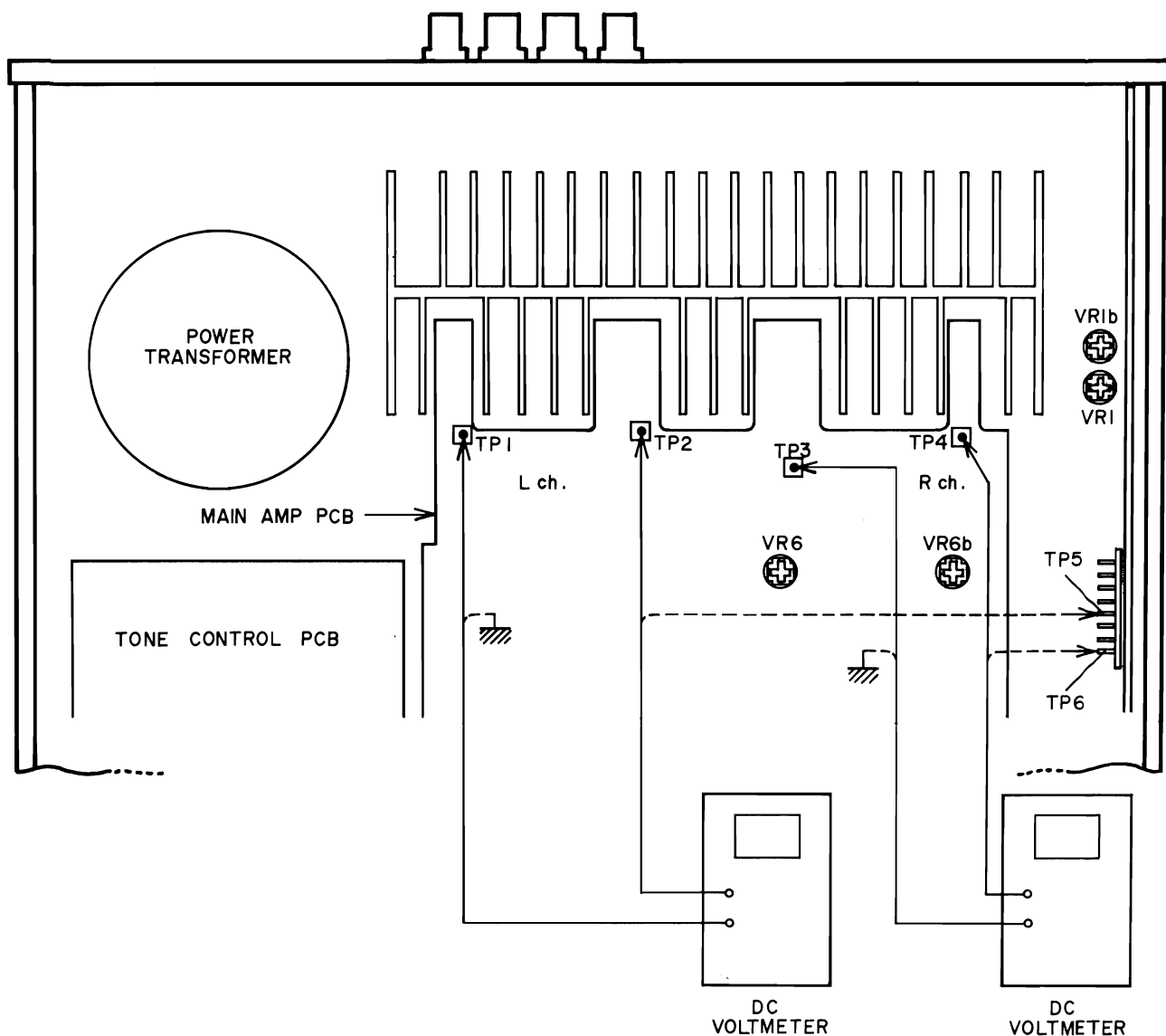

Fig. 6-1

6-1 IDLING CURRENT ADJUSTMENT

After power switch is "ON", connect the DC Voltmeter to the Test points as shown Fig. 6-1.

Adjust VR6 (left channel), VR6b (right channel) so that the DC Voltmeter Reading is $8 \text{ mV} \pm 2 \text{ mV}$.

6-2 EQ AMP DC BALANCE ADJUSTMENT

Function switch to PHONO (MC Range), Connect DC Voltmeter between TP5 (left channel), or TP6 (right channel) and GND.

Adjust VR1 (left channel), VR1b (right channel) so that the DC Voltmeter Reading is $\text{DC } 0\text{V} \pm 1 \text{ mV}$.

VII. CLASSIFICATION OF VARIOUS P.C BOARDS

1. P.C BOARD TITLES AND IDENTIFICATION NUMBER

Title		P.C Board Number	Remarks
MAIN AMP	P.C BOARD	A2020A504A	
VOLUME	P.C BOARD	A2020A504B	
SPEAKER SW	P.C BOARD	A2020A504C	
HEAD PHONE	P.C BOARD	A2020A504D	
SWITCH	P.C BOARD	A2020A504E	
LED (A)	P.C BOARD	A2020A504F	
LED (B)	P.C BOARD	A2020A504G	
LED (C)	P.C BOARD	A2020A504H	
TONE CONTROL	P.C BOARD	A2020A5050	U
TONE CONTROL	P.C BOARD	A2020A5060	C, A
TONE CONTROL	P.C BOARD	A2020A5070	E, V, B, S
EQUALIZER	P.C BOARD	A2021A502A	
INPUT	P.C BOARD	A2021A502B	
POWER SUPPLY	P.C BOARD	A2020D5140	U
POWER SUPPLY	P.C BOARD	A2020D5150	C, A
POWER SUPPLY	P.C BOARD	A2020D5170	E, V, B, S
TERMINAL	P.C BOARD	A2018D5070	V model only

2. COMPOSITION OF VARIOUS P.C BOARDS

1) MAIN AMP P.C BOARD A2020A504A, VOLUME P.C BOARD A2020A504B

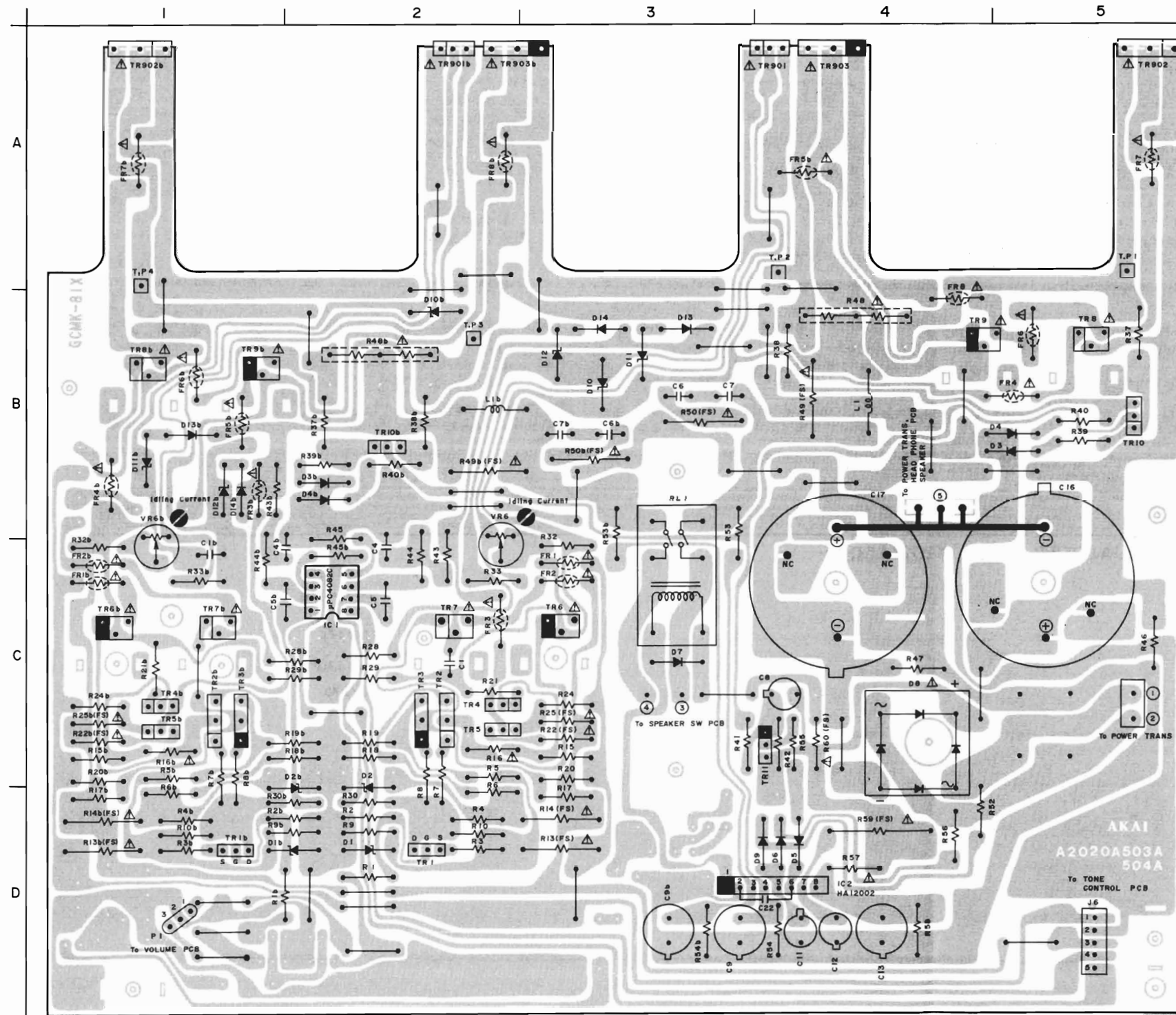

MAIN AMP PCB A2020A504A

LOCATION OF COMPONENTS

- TR
 TR1 ----- D2
 TR1b ----- D1
 TR2 to 5 ----- C2
 TR2b to 7b ----- C1
 TR6 ----- C3
 TR7 ----- C2
 TR8 ----- B5
 TR8b ----- B1
 TR9 ----- B4
 TR9b ----- B1
 TR10 ----- B5
 TR10b ----- B2
 TR11 ----- C4
 TR901 ----- A4
 TR901b ----- A2
 TR902 ----- A5
 TR902b ----- A1
 TR903 ----- A4
 TR903b ----- A2

- IC
 IC1 ----- C2
 IC2 ----- D4

- CONNECTOR
 ①, ② ----- C5
 ③, ④ ----- C3
 ⑤ ----- B4
 P1 ----- D1
 J6 ----- D5

- ● ● = NPN TRANSISTOR
 ● ● ● = PNP TRANSISTOR

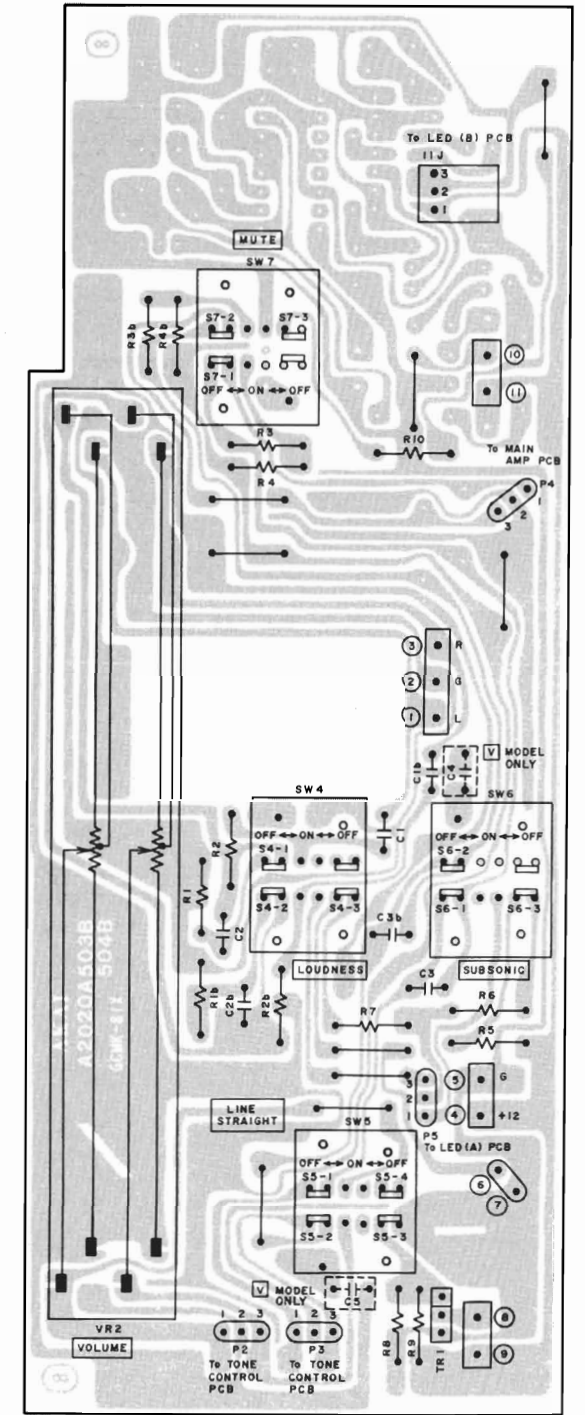

VOLUME PCB A2020A504B

- TR1, 1b ----- 2SK117Y
 TR2, 2b ----- 2SC2690
 TR3, 3b ----- 2SA1220
 TR4, 4b, 5, 5b, 10, 10b ----- 2SC2909
 TR6, 6b ----- 2SA1209
 TR7, 7b ----- 2SC2911

- TR8, 8b ----- 2SC3116
 TR9, 9b ----- 2SA1248
 TR11 ----- 2SA1207
 TR901, 901b ----- 2SC3116
 TR902, 902b ----- 2SC2580
 TR903, 903b ----- 2SA1105

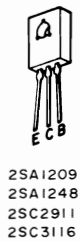

WARNING: Δ INDICATES SAFETY CRITICAL COMPONENTS FOR CONTINUED SAFETY. REPLACE SAFETY CRITICAL COMPONENTS ONLY WITH MANUFACTURER'S RECOMMENDED PARTS.
 AVERTISSEMENT: Δ IL INDIQUE LES COMPOSANTS CRITIQUES DE SÉCURITÉ. POUR MAINTENIR LE DEGRÉ DE SÉCURITÉ DE L'APPAREIL, NE REMPLACER QUE DES PIÈCES RECOMMANDÉES PAR LE FABRICANT

2) EQUALIZER P.C BOARD A2021A502A

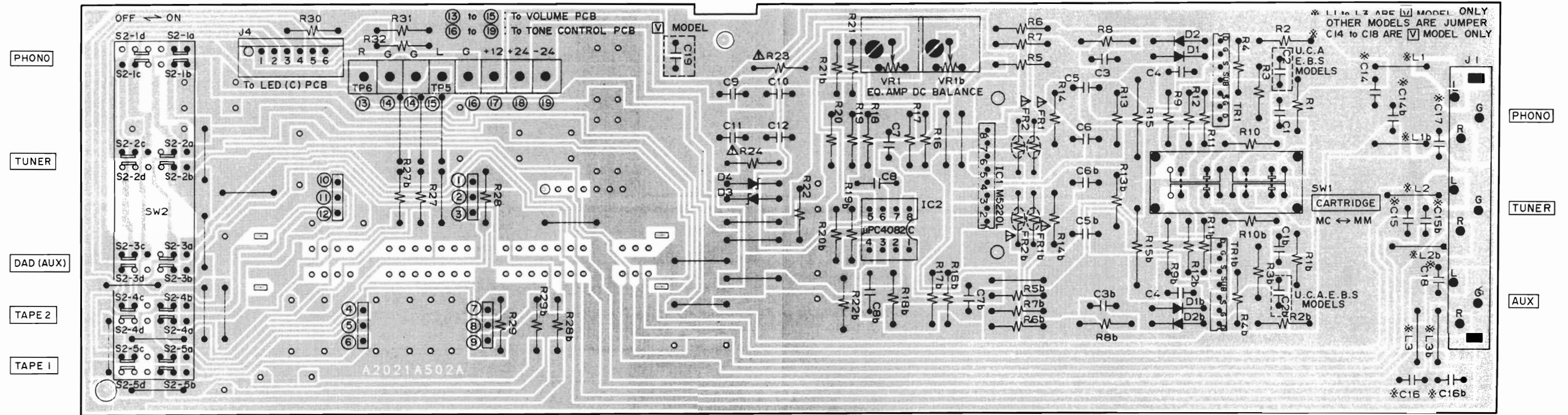

EQUALIZER PCB A2021A502A

WARNING: Δ INDICATES SAFETY CRITICAL COMPONENTS. FOR CONTINUED SAFETY, REPLACE SAFETY CRITICAL COMPONENTS ONLY WITH MANUFACTURER'S RECOMMENDED PARTS.

AVERTISSEMENT: Δ IL INDIQUE LES COMPOSANTS CRITIQUES DE SÉCURITÉ. POUR MAINTENIR LE DEGRÉ DE SÉCURITÉ DE L'APPAREIL, NE REMPLACER QUE DES PIÈCES RECOMMANDÉES PAR LE FABRICANT.

TRI. 1b 2SK270 (BL.V)

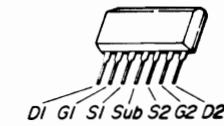

2SK270

3) TONE CONTROL P.C BOARD A2020A5050 **U** , A2020A5060 **C, A** , A2020A5070 **E, V, B, S**

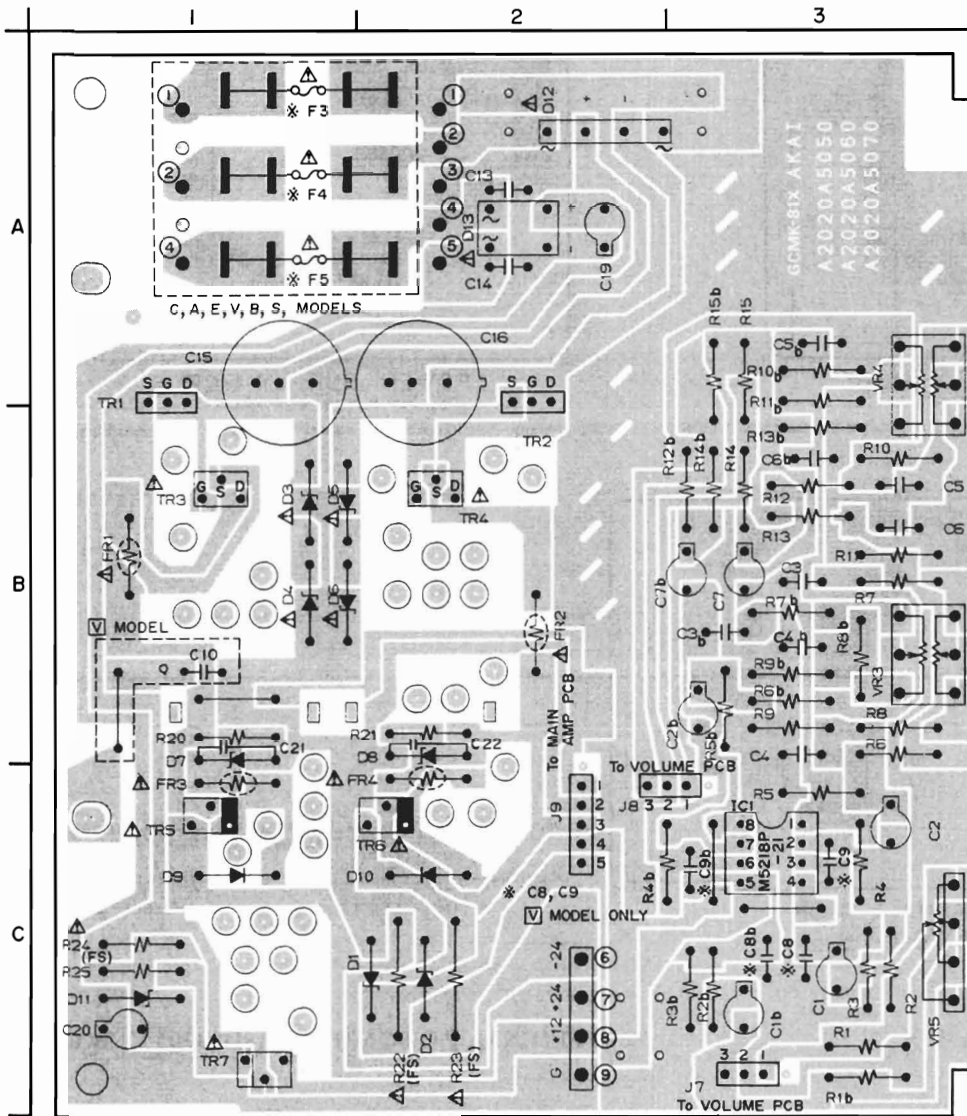

- TR1, 2 2SK246
- TR3 2SK213
- TR4 2SJ76
- TR5 2SC3116
- TR6 2SA1248
- TR7 2SD612K

LOCATION OF COMPONENTS

- TR
- TR1 A1
 - TR2 A2
 - TR3 B1
 - TR4 B2
 - TR5 C1
 - TR6 C2
 - TR7 C1

- IC
- IC1 C3

- CONNECTOR
- ① to ⑤ A2
 - (①, ②, ④) A1
 - ⑥ to ⑨ C2
 - J7 C3
 - J8 C3
 - J9 C2

BASS

TREBLE

BALANCE

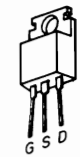

2SK213
2SJ76

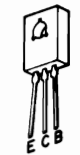

2SC3116
2SA1248
2SD612K



2SK246

TONE CONTROL PCB

- A2020A5050 **U**
- A2020A5060 **C, A**
- A2020A5070 **E, V, B, S**

□○□ = NPN TRANSISTOR

■○□ = PNP TRANSISTOR

*	F3	F4	F5
C, A	1A 125V	1A 125V	1A 125V
E, V, B, S	T1A	T1A	T1A

WARNING: **△** INDICATES SAFETY CRITICAL COMPONENTS FOR CONTINUED SAFETY, REPLACE SAFETY CRITICAL COMPONENTS ONLY WITH MANUFACTURER'S RECOMMENDED PARTS

AVERTISSEMENT: **△** ILL INDIQUE LES COMPOSANTS CRITIQUES DE SÉCURITÉ. POUR MAINTENIR LE DEGRÉ DE SÉCURITÉ DE L'APPAREIL, NE REMPLACER QUE DES PIÈCES RECOMMANDÉES PAR LE FABRICANT

4) POWER SUPPLY P.C BOARD A2020D5140 [U], A2020D5150 [C, A], A2020D5170 [E, V, B, S]

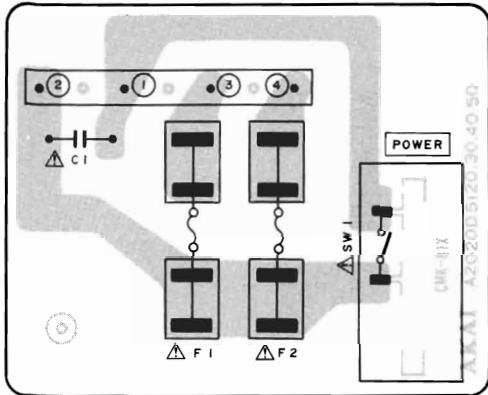

POWER SUPPLY PCB
A2020D5140 [U]

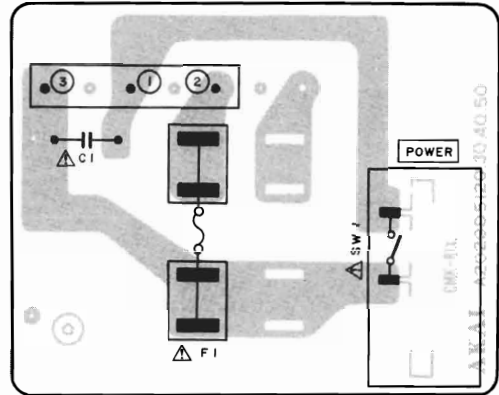

POWER SUPPLY PCB
A2020D5150 [C, A]

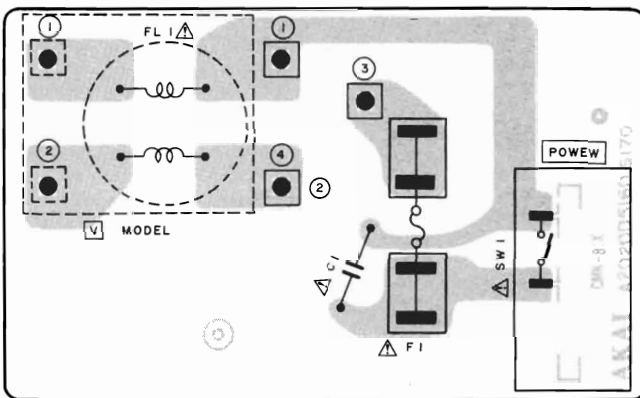

POWER SUPPLY PCB
A2020D5170 [E, V, B, S]

WARNING: ⚠ INDICATES SAFETY CRITICAL COMPONENTS. FOR CONTINUED SAFETY, REPLACE SAFETY CRITICAL COMPONENTS ONLY WITH MANUFACTURER'S RECOMMENDED PARTS.

AVERTISSEMENT: ⚠ IL INDIQUE LES COMPOSANTS CRITIQUES DE SÉCURITÉ. POUR MAINTENIR LE DEGRÉ DE SÉCURITÉ DE L'APPAREIL, NE REMPLACER QUE DES PIÈCES RECOMMANDÉES PAR LE FABRICANT.

5) INPUT P.C BOARD A2021A502B

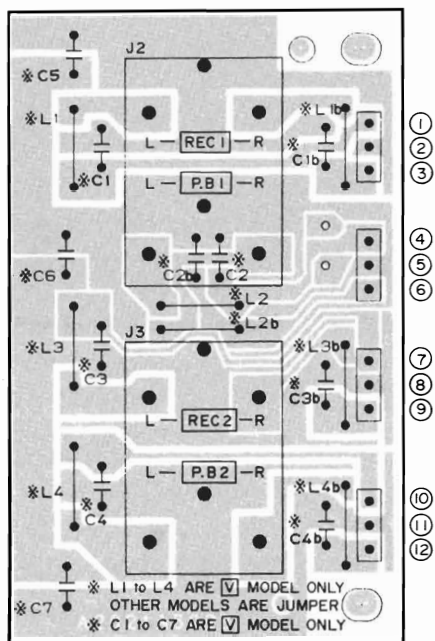

INPUT PCB
A2021A502B

6) TERMINAL P.C BOARD A2018D5070 [V] MODEL

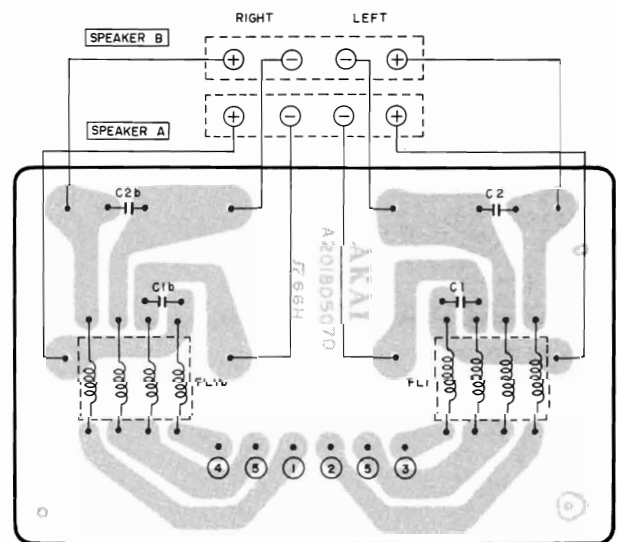

TERMINAL PCB A2018D5070 [V] MODEL

7) OTHER P.C BOARDS

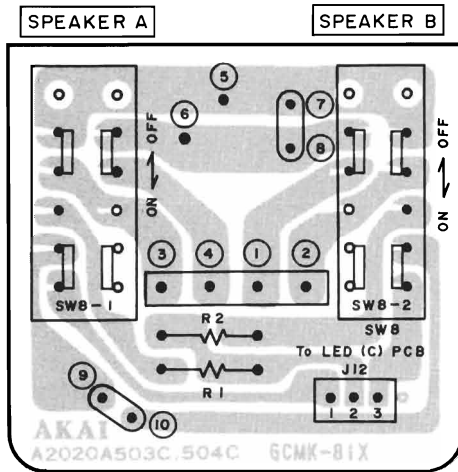

SPEAKER SW PCB
A2020A504C

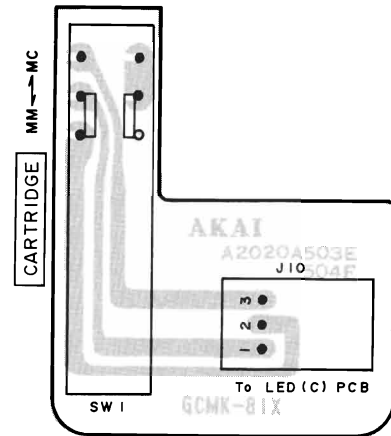

SWITCH PCB
A2020A504E

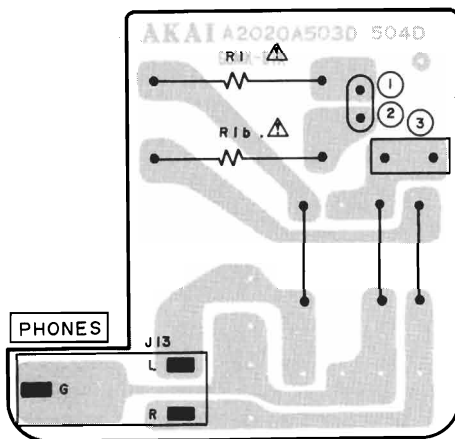

HEAD PHONE PCB
A2020A504D

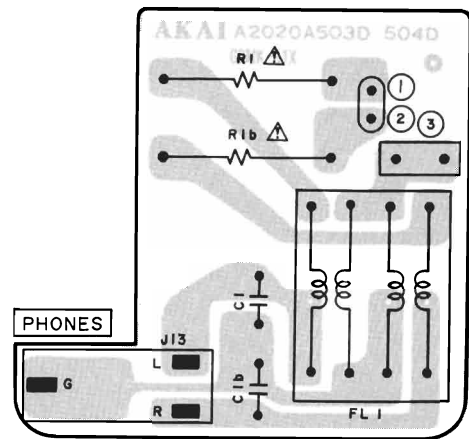

HEAD PHONE PCB
A2020A504D V MODEL

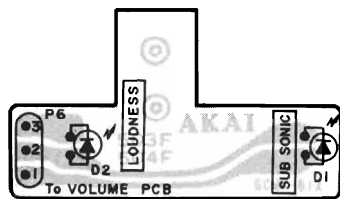

LED (A) PCB
A2020A504F

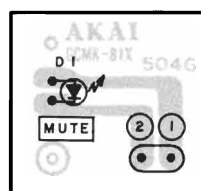

LED (B) PCB
A2020A504G

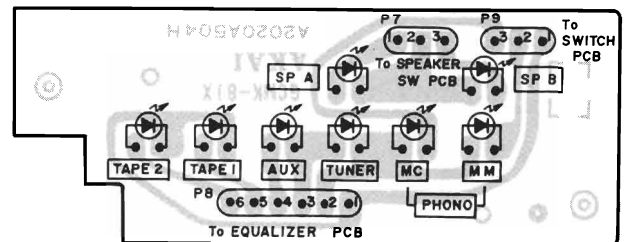

LED (C) PCB
A2020A504H

WARNING: Δ INDICATES SAFETY CRITICAL COMPONENTS. FOR CONTINUED SAFETY, REPLACE SAFETY CRITICAL COMPONENTS ONLY WITH MANUFACTURER'S RECOMMENDED PARTS.

AVERTISSEMENT: Δ IL INDIQUE LES COMPOSANTS CRITIQUES DE SÉCURITÉ. POUR MAINTENIR LE DEGRÉ DE SÉCURITÉ DE L'APPAREIL, NE REMPLACER QUE DES PIÈCES RECOMMANDÉES PAR LE FABRICANT.

MEMO

SECTION 3

PARTS LIST

TABLE OF CONTENTS

RECOMMENDED SPARE PARTS	19
1. MAIN AMP U5 P.C BOARD BLOCK	20
2. TONE CONTROL P.C BOARD BLOCK	20
3. EQUALIZER P.C BOARD BLOCK	21
4. POWER SUPPLY U5-1 P.C BOARD BLOCK (U, C, A)	21
5. POWER SUPPLY U5-2 P.C BOARD BLOCK (E, V, B, S)	21
6. TERMINAL P.C BOARD BLOCK (V ONLY)	21
7. ASSEMBLY BLOCK	22
8. FINAL ASSEMBLY BLOCK	23
INDEX	24

Resistor and Capacitor which is not listed in this parts list, please refer to COMMON LIST FOR SERVICE PARTS.

ATTENTION

1. When placing an order for parts, be sure to list the parts no., model no., and description. There are instances in which if any of this information is omitted, parts cannot be shipped or the wrong parts will be delivered.
2. Please be careful not to make a mistake in the parts no. If the parts no. is in error, a part different from the one ordered may be delivered.
3. Because parts number and parts unit supply in the Preliminary Parts List may be partially changed, please use this parts list for all future reference.

HOW TO USE THIS PARTS LIST

1. This Parts List shows the parts that are considered necessary for repairs. Other parts, such as resistors and capacitors, are shown in the "Common List for Service Parts". Select and order such parts from the "Common List for Service Parts".
2. The Recommended Spare Parts shows those parts in the Parts List which are considered particularly important for service.
3. Parts not shown in the Parts List and "Common List for Service Parts" will not be supplied in principle.
4. How to read list
 - a) Mechanism Block
 - b) P.C Board Block

2. HEAD BASE BLOCK

REF. NO.	PARTS NO.	DESCRIPTION
2-1x	BH-T2023A320A	HEAD BASE BLOCK GX-F66R
2-2	HP-H2206A010A	HEAD R/P PR4-8FU C
2-3	ZS-477876	PAN20x03STL CMT
2-4	ZS-536488	BID20x08STL CMT
2-5	ZG-402895	CS ANGLE ADJUST SPRING

SP (Service Parts) Classification

A small "x" indicates the inability to show that particular part in the Photo or Illustration.

This number corresponds with the individual parts index number in that figure

This number corresponds with the Figure Number

6. SYS. CON. P.C BOARD BLOCK

REF. NO.	PARTS NO.	DESCRIPTION
6-1	BA-T2034A070A	PC SYS CON BLK GX-F44 R
6-IC1	EI-324536	IC HD14049BP
6-IC2	EI-336801	IC MB8841-564M
6-IC3	EI-331661	IC SN7405N
6-IC4	EI-336725	IC M54527P
6-TR1to4	ET-200985	TR 2SC2603 F,G
6-TR5to28	ET-554657	TR 2SA733A P,Q
6-D1	ED-318292	D SILICON H 1S2473T-77 T2 6
6-D2to4	ED-308952	D GERMA V 1K34A-LR F07
6-D5to10	ED-318292	D SILICON H 1S2473T-77 T2 6
6-X1	EI-318384	OSC X'TAL NC-18C 3.579545MHZ

SP (Service Parts) Classification

This reference numbers corresponds with symbol numbers of Schematic Diagrams.

5. Both the kind of part and installation position can be determined by the Parts Number. To determine where a parts number is listed, utilize Parts Index at end of Parts List. It is necessary first of all to find the Parts Number. This can be accomplished by using the Reference Number listed at right of parts number in the Parts Index.

WARNING

⚠ INDICATES SAFETY CRITICAL COMPONENTS. FOR CONTINUED SAFETY, REPLACE SAFETY CRITICAL COMPONENTS ONLY WITH MANUFACTURER'S RECOMMENDED PARTS.

AVERTISSEMENT

⚠ IL INDIQUE LES COMPOSANTS CRITIQUES DE SURETE. POUR MAINTENIR LE DEGRE DE SECURITE DE L'APPAREIL NE REMPLACER LES COMPOSANTS DONT LE FONCTIONNEMENT EST CRITIQUE POUR LA SECURITE QUE PAR DES PIECES RECOMMANDEES PAR LE FABRICANT.

RECOMMENDED SPARE PARTS

Because, if the parts listed below are on hand, almost any repair can be accomplished, we suggest that you stock these Recommended Spare Parts Items.

NO.	PARTS NO.	DESCRIPTION
1	BT-345621	△ TRANS POWER AM-U5T-30 (C,A)
2	BT-345622	△ TRANS POWER AM-U5T-40 (E,V)
3	BT-345623	△ TRANS POWER AM-U5T-50 (B,S)
4	BT-345620	△ TRANS POWER AM-U5T-70 (U)
5	ED-345555	△ D SILICON DBB10C 200/1.0A
6	ED-348786	△ D SILICON RB154 400/1.5A
7	ED-348836	△ D SILICON RB602U 200/6.0A
8	ED-348860	D LED GL4NG2 GRN
9	ED-348861	D LED GL4PR2 RED
10	ED-337391	D LED GL5NG6 GRN
11	ED-337153	D SILICON H DS446FA5 F10
12	ED-301911	D SILICON H DS448
13	ED-346564	D ZENER H HZ15L 1
14	ED-330219	D ZENER H HZ20L 2
15	ED-346575	D ZENER H HZ22L 3
16	ED-346576	D ZENER H HZ24L 1
17	ED-345615	D ZENER H 05Z12 Y
18	ED-324194	D ZENER H 05Z5.1 X
19	ED-323535	D ZENER H 05Z8.2 X
20	EF-623103	△ FUSE SEMKO T 250V 1.00A
21	EF-691007	△ FUSE SEMKO T 250V 3.15A (U,E,V,B,S)
22	EF-310229	△ FUSE TSC 125V 1.00A
23	EF-346115	△ FUSE TSC 125V 6.30A (C,A)
24	EI-345474	△ IC HA12002
25	EI-344764	IC M5218P-21
26	EI-348785	IC M5220L
27	EI-337360	IC μPC4082C
28	EI-348865	IC μPC4082C
29	EJ-337404	PIN J AJC-052-ABB P 6P
30	EL-348854	PL CODE 12.0V 220MA 250/250(IN902)
31	EL-348852	PL CODE 14.0V 100MA 100/100(IN901)
32	EQ-348789	RELAY POW JC2AD 48V
33	ER-319455	△ R FUSE ERD3FS S10 1/4W 10R0G
34	ER-345751	△ R FUSE ERD2FC S10 1/4W 15R0G
35	ER-338000	△ R FUSE ERD2FC S10 1/4W 2200G
36	ER-345618	△ R FUSE ERD2FC S10 1/4W 2700G
37	ER-345619	△ R FUSE ERD2FC S10 1/4W 3301G
38	ER-318248	△ R FUSE ERD2FC S10 1/4W 47R0G
39	ER-337756	△ R FUSE ERD2FC S10 1/4W 4700G
40	ES-348862	△ SW PUSH ESB-70405T 01-1 UC(C,A)
41	ES-343688	△ SW PUSH ESB-90279S 01-1EBV (U,E,V,B,S)
42	ES-343364	△ SW SELECTOR 0240#01 01-4 (U)
43	ES-345652	SW PUSH ESB-62907 5-THROW
44	ES-345481	SW PUSH SEA12 04-2N
45	ES-348841	SW PUSH SEA12 04-2S
46	ES-348845	SW PUSH SUL221S 2-THROW
47	ES-348847	SW REMOTE O SUR512 02-2
48	ES-337388	SW REMOTE S SSR24352 04-3
49	ET-348788	△ TR FET 2SJ76
50	ET-348787	△ TR FET 2SK213
51	ET-345629	△ TR 2SA1105 O,Y
52	ET-348829	△ TR 2SA1209 S,T
53	ET-345626	△ TR 2SA1248 S,T
54	ET-345628	△ TR 2SC2580 O,Y
55	ET-348831	△ TR 2SC2911 S,T
56	ET-345625	△ TR 2SC3116 S,T
57	ET-310148	△ TR 2SD612K E,F
58	ET-322353	TR FET 2SK117 Y
59	ET-337759	TR FET 2SK246 GR
60	ET-345614	TR FET 2SK270 BL,V
61	ET-348832	TR 2SA1207 S,T
62	ET-348834	TR 2SA1220 Q,P
63	ET-348835	TR 2SC2690 Q,P
64	ET-348830	TR 2SC2909 S,T
65	ET-348844	TR 2SD467C C
66	EV-361800	R S-FIX H SR19R 3P 0.15W 471
67	EV-338118	R S-FIX V H1052A 3P 0.15W 104
68	EV-337308	VR SLIDE 100P2SV0B B254

1. MAIN AMP U5 P.C BOARD BLOCK

REF. NO.	PARTS NO.	DESCRIPTION
1-1U	BA-A2021A050A	PC MAIN U5 BLK AM-U5 (U) (EXCEPT V)
1-1V	BA-A2021A050B	PC MAIN U5 BLK AM-U5 (V)

MAIN AMP U5 P.C BOARD

1-IC1A	EI-337360	IC μ PC4082C
1-IC2A	EI-345474	Δ IC HA12002
1-TR1A	ET-322353	TR FET 2SK117 Y
1-TR2A	ET-348835	TR 2SC2690 Q,P
1-TR3A	ET-348834	TR 2SA1220 Q,P
1-TR4A,5A	ET-348830	TR 2SC2909 S,T
1-TR6A	ET-348829	Δ TR 2SA1209 S,T
1-TR7A	ET-348831	Δ TR 2SC2911 S,T
1-TR8A	ET-345625	Δ TR 2SC3116 S,T
1-TR9A	ET-345626	Δ TR 2SA1248 S,T
1-TR10A	ET-348830	TR 2SC2909 S,T
1-TR11A	ET-348832	TR 2SA1207 S,T
1-D1A,2A	ED-330219	D ZENER H HZ20L 2
1-D3Ato5A	ED-301911	D SILICON H DS448
1-D6A,7A	ED-337153	D SILICON H DS446FA5 F10
1-D8A	ED-348836	Δ D SILICON RB602U 200/6.0A
1-D9A	ED-337153	D SILICON H DS446FA5 F10
1-D10A	ED-324194	D ZENER H 05Z5.1 X
1-D11A,12A	ED-323535	D ZENER H 05Z8.2 X
1-D13A,14A	ED-301911	D SILICON H DS448
1-VR6A	EV-361800	R S-FIX H SR19R 3P 0.15W 471
1-L1A	EO-332116	COIL FIX 2 103AK-006A 2.2UH
1-RL1A	EQ-348789	RELAY POW JC2AD 48V
1-FR1A,2A	ER-345618	Δ R FUSE ERD2FC S10 1/4W 2700G
1-FR3A	ER-345619	Δ R FUSE ERD2FC S10 1/4W 3301G
1-FR4A,5A	ER-319455	Δ R FUSE ERD2FC S10 1/4W 10R0G
1-FR6A	ER-337756	Δ R FUSE ERD2FC S10 1/4W 4700G
1-FR7A,8A	ER-345751	Δ R FUSE ERD2FC S10 1/4W 15R0G
1-R13A,14A	ER-337773	Δ R OMF H S15 FS 1W 222J
1-R22A	ER-328068	Δ R CB H SNP FS RDS 1/4W 562J
1-R25A	ER-333429	Δ R CB H S10 FS RDS 1/4W 682J
1-R48A	ER-345616	Δ R CT W R33+R33 5W
1-R49A,50A	ER-337754	Δ R OMF H S15 FS 1W 100J
1-R59A	ER-337755	Δ R OMF H S20 FS 2W 222J
1-R60A	ER-324480	Δ R CB H S10 FS RDS 1/4W 470J
1-C1A	EC-345656	C PP V F05 PP 473J 50DC
1-C4A	EC-345656	C PP V F05 PP 473J 50DC
1-C16A,17A	EC-345627	C EC V SNP 123M 56.0DC

VOLUME P.C BOARD

1-TR1B	ET-348844	TR 2SD467C C
1-SW4B	ES-345481	SW PUSH SEA12 04-2N
1-SW5 Bto7B	ES-348841	SW PUSH SEA12 04-2S
1-VR2B	EV-337308	VR SLIDE 100P2SV0B B254
1-C1B	EC-344155	C PP V F05 PP 181J 50DC
1-C2B	EC-345655	C PP V F05 PP 223J 50DC

SPEAKER SW P.C BOARD

1-SW8C	ES-348845	SW PUSH SUL221S 2-THROW
--------	-----------	-------------------------

HEAD PHONE P.C BOARD

1-J13D	EJ-348846	PHONE J 3P HLJ0540 6.3
1-FL1D	EO-342936	COIL BALUN (V)
1-R1D	ER-624756	Δ R OMF H FS 2W 331J

SWITCH P.C BOARD

1-SW1E	ES-348847	SW REMOTE O SUR512 02-2
--------	-----------	-------------------------

LED (A) P.C BOARD

1-D1F,2F	ED-337391	D LED GL5NG6 GRN
----------	-----------	------------------

REF. NO.	PARTS NO.	DESCRIPTION
LED (B) P.C BOARD		
1-D1G	ED-348861	D LED GL4PR2 RED
LED (C) P.C BOARD		
1-D1Hto8H	ED-348860	D LED GL4NG2 GRN

2. TONE CONTROL P.C BOARD BLOCK

REF. NO.	PARTS NO.	DESCRIPTION
2-1U	BA-A2021A060A	PC TONE BLK AM-U5 (U)
2-1C	BA-A2021A060B	PC TONE BLK AM-U5 (C) (C,A)
2-1E	BA-A2021A060C	PC TONE BLK AM-U5 (E)(E,B,S)
2-1V	BA-A2021A060D	PC TONE BLK AM-U5 (V)

TONE CONTROL P.C BOARD

2-IC1	EI-344764	IC M5218P-21
2-TR1,2	ET-337759	TR FET 2SK246 GR
2-TR3	ET-348787	Δ TR FET 2SK213
2-TR4	ET-348788	Δ TR FET 2SJ76
2-TR5	ET-345625	Δ TR 2SC3116 S,T
2-TR6	ET-345626	Δ TR 2SA1248 S,T
2-TR7	ET-310148	Δ TR 2SD612K E,F
2-D1,2	ED-346564	D ZENER H HZ15L 1
2-D3	ED-346575	D ZENER H HZ22L 3
2-D4	ED-346576	D ZENER H HZ24L 1
2-D5	ED-346575	D ZENER H HZ22L 3
2-D6to8	ED-346576	D ZENER H HZ24L 1
2-D9,10	ED-301911	D SILICON H DS448
2-D11	ED-345615	D ZENER H 05Z12 Y
2-D12	ED-348786	Δ D SILICON RB154 400/1.5A
2-D13	ED-345555	Δ D SILICON DBB10C 200/1.0A
2-FR1,2	ER-319455	Δ R FUSE ERD2FC S10 1/4W 10R0G
2-FR3,4	ER-318248	Δ R FUSE ERD2FC S10 1/4W 47R0G
2-R22,23	ER-306127	Δ R CB H S15 FS RDS 1/2W 681J
2-R24	ER-316802	R CB H S10 FS RDS 1/4W 471J
2-F3Cto5C	EF-310229	Δ FUSE TSC 125V 1.00A (C,A)
2-F3Eto5E	EF-623103	Δ FUSE SEMKO T 250V 1.00A (E,V,B,S)

3. EQUALIZER P.C BOARD BLOCK

REF. NO.	PARTS NO.	DESCRIPTION
3-1U	BA-A2021A040A	PC EQ BLK AM-U5 (U) (EXCEPT V)
3-1V	BA-A2021A040B	PC EQ BLK AM-U5 (V)
EQUALIZER P.C BOARD		
3-IC1A	EI-348785	IC M5220L
3-IC2A	EI-348865	IC μ PC4082C
3-TR1A	ET-345614	TR FET 2SK270 BL,V
3-D1A,2A	ED-301911	D SILICON H DS448
3-D3A,4A	ED-346564	D ZENER H HZ15L 1
3-J1A	EJ-337404	PIN J AJC-052-ABB P 6P
3-SW1A	ES-337388	SW REMOTE S SSR24352 04-3
3-SW2A	ES-345652	SW PUSH ESB-62907 5-THROW
3-VR1A	EV-338118	R S-FIX V H1052A 3P 0.15W
3-L1A	EO-337684	COIL FIX 2 FL12R751E 750UH 104 (V)
3-L2A,3A	EO-336934	COIL FIX 1 LAL03KH 2.20UH M (V)
3-FR1A,2A	ER-338000	Δ R FUSE ERD2FC S10 1/4W 2200G
3-R11A	ER-346864	R MF H F10 1/4W 75R0F
3-R12A	ER-345664	R MF H F10 1/4W 8R20F
3-R13A	ER-338325	R MF H 1/4W 4302F
3-R14A	ER-338078	R MF H F10 1/4W 3601F
3-R23A,24A	ER-327198	R CB H S10 FS RDS 1/4W 122J
3-C1A	EC-350745	C STY V CUT CQ09S2B 102J 125DC
3-C2A	EC-350675	C STY V CUT CQ09S2B 331J 125DC (EXCEPT V)
3-C3A	EC-344478	C PP V F05 PP 561J 50DC
3-C4A	EC-345607	C PP V F05 PP 152J 50DC
3-C5A	EC-345608	C PP V F05 PP 7442G 50DC
3-C6A	EC-345609	C PP V F05 PP 2102G 50DC
3-C7A	EC-345655	C PP V F05 PP 223J 50DC
3-C9Ato12A	EC-345655	C PP V F05 PP 223J 50DC
3-C14A	EC-350675	C STY V CUT CQ09S2B 331J 125DC (V)
INPUT P.C BOARD		
3-J2B,3B	EJ-336915	PIN J AJC-054-ABB P 4P
3-L1Bto4B	EO-336934	COIL FIX 1 LAL03KH 2.20UH M (V)

4. POWER SUPPLY U5-1 P.C BOARD BLOCK (U, C, A)

REF. NO.	PARTS NO.	DESCRIPTION
4-SW1U	ES-343688	Δ SW PUSH ESB-90279S 01-1EBV (U)
4-SW1C	ES-348862	Δ SW PUSH ESB-70405T 01-1 UC (C,A)
4-C1U	EC-320548	Δ C CE V F 103Z 250AC (U)
4-C1C	EC-314688	Δ C CE V FZ 103P 125AC (C,A)
4-F1U,2U	EF-691007	Δ FUSE SEMKO T 250V 3.15A (U)
4-F1C	EF-346115	Δ FUSE TSC 125V 6.30A (C,A)

5. POWER SUPPLY U5-2 P.C BOARD BLOCK (E, V, B, S)

REF. NO.	PARTS NO.	DESCRIPTION
5-SW1	ES-343688	Δ SW PUSH ESB-90279S 01-1EBV
5-C1	EC-338411	Δ C CE V FZ 103P 400AC
5-F1	EF-691007	Δ FUSE SEMKO T 250V 3.15A

6. TERMINAL P.C BOARD BLOCK (V ONLY)

REF. NO.	PARTS NO.	DESCRIPTION
6-J1	EJ-342935	TERMINAL W/SCREW YKD31-0132 P 8P
6-FL1	EO-342936	COIL BALUN
6-C1,2	EC-324623	C CE V F05 B 103K 50DC

7. ASSEMBLY BLOCK

REF. NO.	PARTS NO.	DESCRIPTION
HEAT SINK BLOCK		
7-1	ET-345625	△ TR 2SC3116 S,T (TR901)
7-2	ET-345628	△ TR 2SC2580 O,Y (TR902)
7-3	ET-345629	△ TR 2SA1105 O,Y (TR903)
ASSEMBLY BLOCK		
7-4U	BT-345620	△ TRANS POWER AM-U5T-70 (U) (T901)
7-4C	BT-345621	△ TRANS POWER AM-U5T-30 (C,A) (T901)
7-4E	BT-345622	△ TRANS POWER AM-U5T-40 (E,V) (T901)
7-4B	BT-345623	△ TRANS POWER AM-U5T-50 (B,S) (T901)
7-5	ZS-345624	ST PAN40x08STL CMT CUP
7-6U	SP-345583A	PANEL REAR AM-U5 (U)
7-6C	SP-345583B	PANEL REAR AM-U5 (C,A)
7-6E	SP-345583C	PANEL REAR AM-U5 (E,V)
7-6B	SP-345583D	PANEL REAR AM-U5 (B,S)
7-7	EJ-329610	TERMINAL W/SCREW UB-0067 L 1P (TM901)
7-8	ZS-308846	T2BR30x08STL BZN PROJECTION
7-9	EJ-337406	TERMINAL W/SCREW ANB-024-AAA S 8P (TM902) (EXCEPT V)
7-10	ZS-522865	T2BR30x12STL BNI
7-11	EJ-337405	△ SOCKET OUTLET S2T733T164 JUC 3x2P (U,C,A)
7-12U	EW-374894	△ AC CORD 2 CORES VM-0129A, VFF U/T (U)
7-12C	EW-343363	△ AC CORD 2 CORES KP-8, SPT-2 105C UC (C)
7-12A	EW-305691	△ AC CORD 2 CORES KP-8, SPT-1 UC (A)
7-12E	EW-346251	△ AC CORD 2 CORES VM0364, NR N/815 EV (E,V)
7-12B	EW-346249	△ AC CORD 2 CORES LCFL2x0.75 B (B)
7-12S	EW-336924	△ AC CORD 2 CORES KP-560, LTSA-2F S (S)
7-13	EZ-631945	STRAIN RELIEF SR-4N-4
7-14	ES-343364	△ SW SELECTOR 0240#01 01-4 (SW901) (U)
7-15	ZS-309315	T2BR30x10STL BNI (U)
7-16	EL-348852	PL CODE 14.0V 100MA 100/100 (IN901)
7-17	EL-348854	PL CODE 12.0V 220MA 250/250 (IN902)
7-18	ES-348858	SW REMOTE B SWR1306 L=287
7-19x	ZW-305013	RV POP32 (A)
7-20	SA-312465	CIRCULAR FOOT (A) PART CA

ASSEMBLY BLOCK

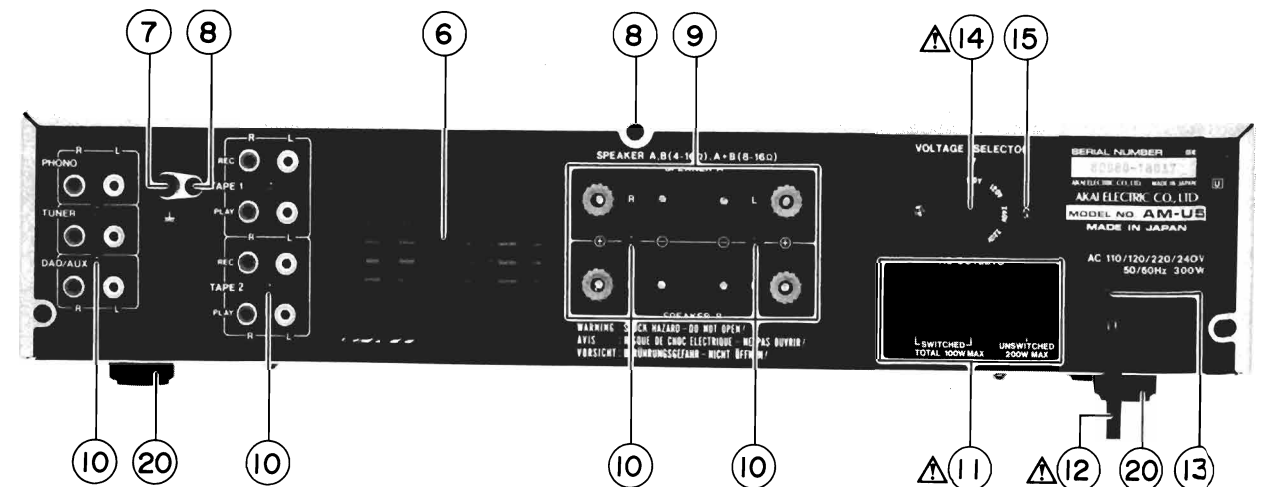
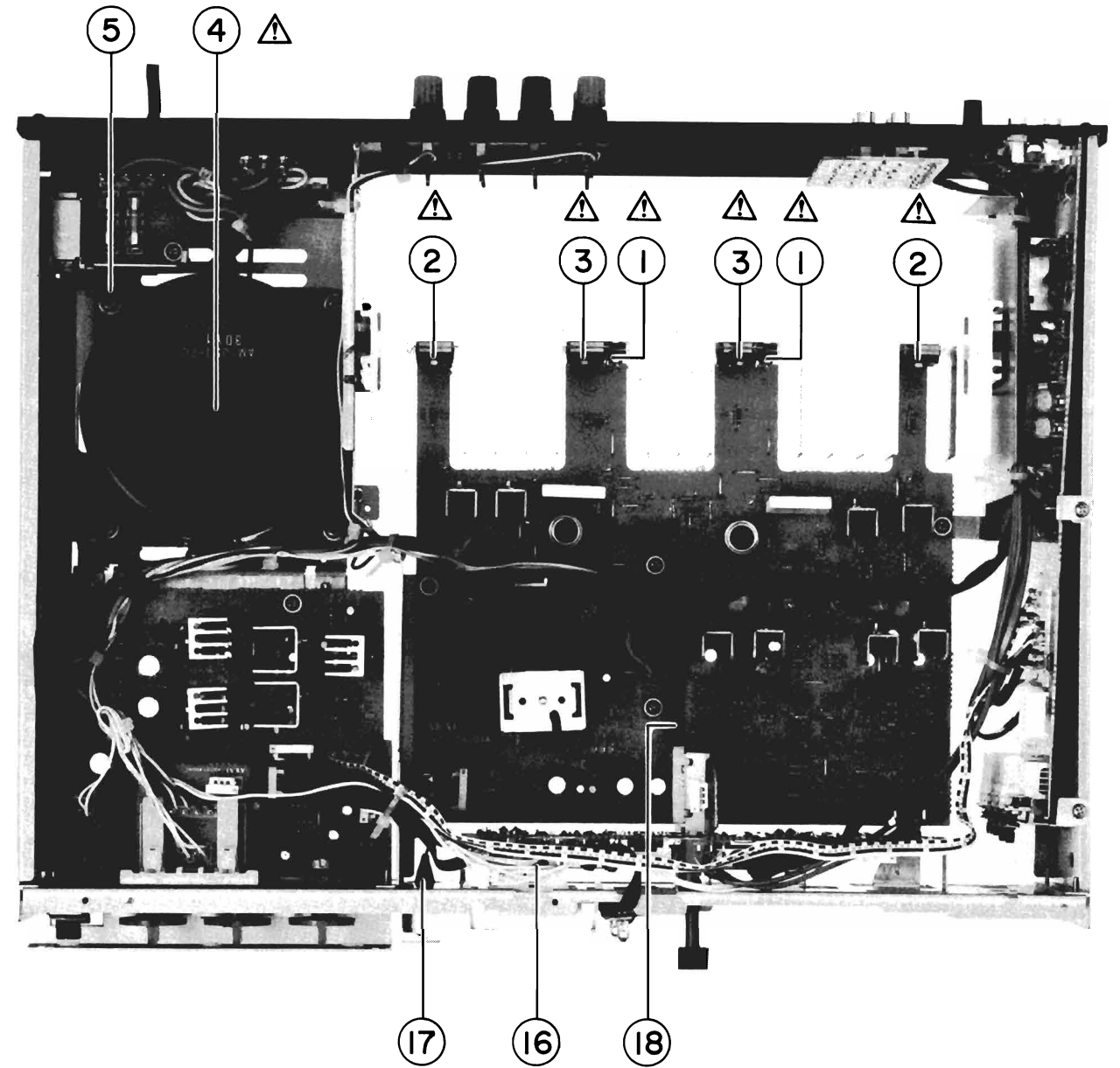

FINAL ASSEMBLY BLOCK

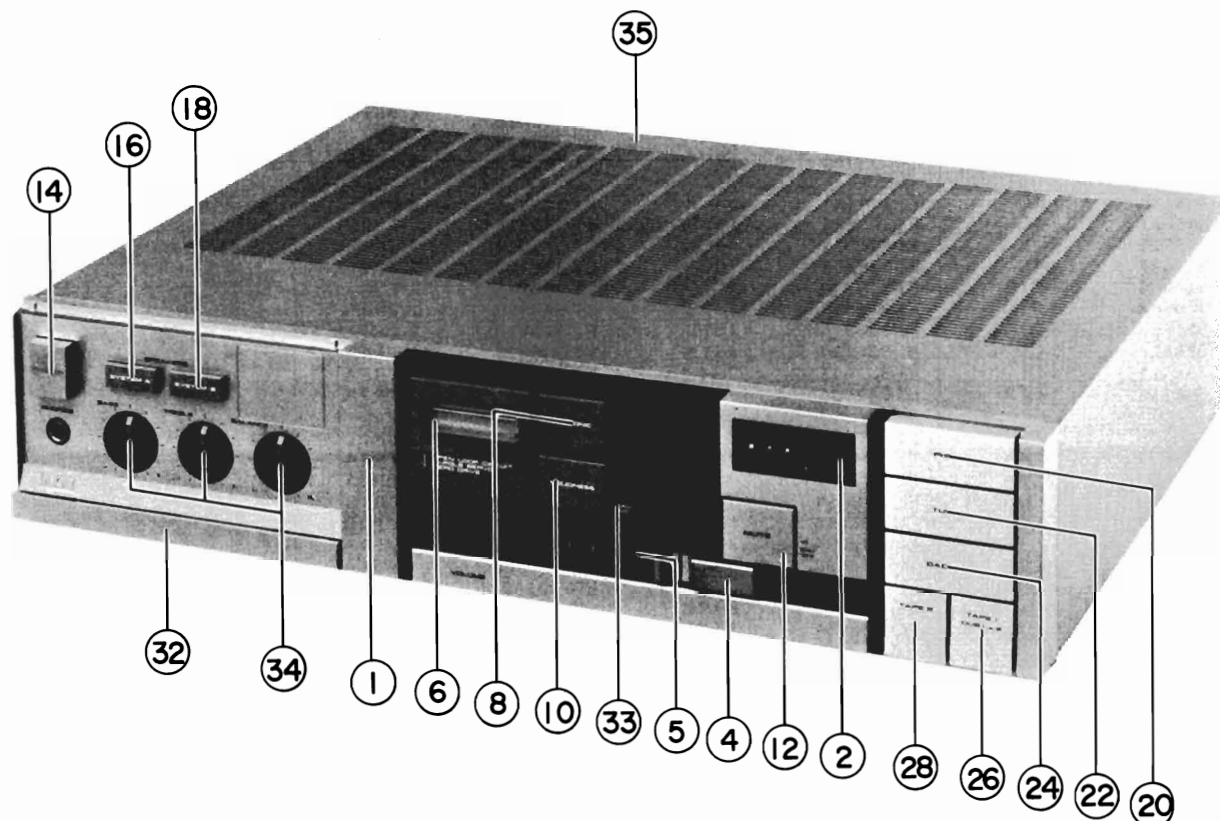

8. FINAL ASSEMBLY BLOCK

REF. NO.	PARTS NO.	DESCRIPTION
8-1	BD-A2021A080A	PANEL FRONT BLK AM-U5
8-1P	BD-A2021A080B	PANEL FRONT BLK AM-U5-P
PANEL FRONT BLOCK		
8-2	SP-348759	WINDOW DISPLAY (A)
8-3x	SZ-348765	HOLDER VOLUME
8-4	SK-348762A	KNOB VOLUME
8-4P	SK-348762B	KNOB VOLUME-P
8-5	SP-348741A	WINDOW VOLUME AM-U5
8-6	SK-B348754	KNOB PUSH LINE STRAIGHT
PART		
8-7x	ZG-323317	SP (C)
8-8	SK-B348752A	KNOB PUSH SUBSONIC PART
8-8P	SK-B348752B	KNOB PUSH SUBSONIC-P PART
8-9x	ZG-322579	SP (A)
8-10	SK-B348752C	KNOB PUSH LOUDNESS PART
8-10P	SK-B348752D	KNOB PUSH LOUDNESS-P PART
8-11x	ZG-322579	SP (A)
8-12	SK-348750C	KNOB PUSH MUTE
8-12P	SK-348750D	KNOB PUSH MUTE-P
8-13x	ZG-322579	SP (A)
8-14	SK-342820A	KNOB POWER
8-14P	SK-342820B	KNOB POWER-P
8-15x	ZG-322579	SP (A)
8-16	SK-348757A	KNOB PUSH SYSTEM (A)
8-16P	SK-348757B	KNOB PUSH SYSTEM (A)-P
8-17	ZG-348769	SP PUSH
8-18	SK-348757C	KNOB PUSH SYSTEM (B)
8-18P	SK-348757D	KNOB PUSH SYSTEM (B)-P

REF. NO.	PARTS NO.	DESCRIPTION
8-19x	ZG-348769	SP PUSH
8-20	SK-B348747A	KNOB CAP PHONO PART
8-20P	SK-B348747B	KNOB CAP PHONO-P PART
8-21x	ZG-323317	SP (C)
8-22	SK-B348748A	KNOB CAP TUNER PART
8-22P	SK-B348748B	KNOB CAP TUNER-P PART
8-23x	ZG-349041	SP PUSH (B)
8-24	SK-B348748C	KNOB CAP AUX PART
8-24P	SK-B348748D	KNOB CAP AUX-P PART
8-25x	ZG-349041	SP PUSH (B)
8-26	SK-B348749E	KNOB CAP TAPE1 DUB1-2 PART
8-26P	SK-B348749F	KNOB CAP TAPE1 DUB1-2-P PART
8-27x	ZG-322579	SP (A)
8-28	SK-B348749C	KNOB CAP TAPE2 PART
8-28P	SK-B348749D	KNOB CAP TAPE2-P PART
8-29x	ZG-322579	SP (A)
PANEL DOOR BLOCK		
8-30x	ZG-345575A	SP PLATE (L)
8-31x	ZG-345575B	SP PLATE (R)
8-32	SP-345587A	PANEL DOOR AM-U5
8-32P	SP-345587B	PANEL DOOR AM-U5-P
FINAL ASSEMBLY BLOCK		
8-33	SK-348751	KNOB PUSH MM/MC
8-34	SK-348756C	KNOB ROTARY AM-U5
8-34P	SK-348756B	KNOB ROTARY-P
8-35	SP-345589A	COVER UPPER
8-35P	SP-345589B	COVER UPPER-P

SYMBOL FOR COLOR VARIATION

NONE - SILVER

P - PEARL SHADOW

INDEX

PARTS NO.	REF. NO.	PARTS NO.	REF. NO.	PARTS NO.	REF. NO.	PARTS NO.	REF. NO.
BA-A2021A040A	3-1U	EF-310229	2-F5C	ES-348862	4-SW1C	ZG-323317	8-7x
BA-A2021A040B	3-1V	EF-310229	2-F4C	ET-310148	2-TR7	ZG-323317	8-21x
BA-A2021A050A	1-1U	EF-346115	4-F1C	ET-322353	1-TR1A	ZG-345575A	8-30x
BA-A2021A050B	1-1V	EF-623103	2-F4E	ET-337759	2-TR2	ZG-345575B	8-31x
BA-A2021A060A	2-1U	EF-623103	2-F5E	ET-337759	2-TR1	ZG-348769	8-19x
BA-A2021A060B	2-1C	EF-623103	2-F3E	ET-345614	3-TR1A	ZG-348769	8-17
BA-A2021A060C	2-1E	EF-691007	4-F2U	ET-345625	1-TR8A	ZG-349041	8-25x
BA-A2021A060D	2-1V	EF-691007	4-F1U	ET-345625	2-TR5	ZG-349041	8-23x
BD-A2021A080A	8-1	EF-691007	5-F1	ET-345625	7-1	ZG-308846	7-8
BD-A2021A080B	8-1P	EI-337360	1-IC1A	ET-345626	1-TR9A	ZS-309315	7-15
BT-345620	7-4U	EI-344764	2-IC1	ET-345626	2-TR6	ZS-345624	7-5
BT-345621	7-4C	EI-345474	1-IC2A	ET-345628	7-2	ZS-522865	7-10
BT-345622	7-4E	EI-348785	3-IC1A	ET-345629	7-3	ZW-305013	7-19x
BT-345623	7-4B	EI-348865	3-IC2A	ET-348787	2-TR3		
EC-314688	4-C1C	EJ-329610	7-7	ET-348788	2-TR4		
EC-320548	4-C1U	EJ-336915	3-J3B	ET-348829	1-TR6A		
EC-324623	6-C1	EJ-336915	3-J2B	ET-348830	1-TR10A		
EC-324623	6-C2	EJ-337404	3-J1A	ET-348830	1-TR4A		
EC-338411	5-C1	EJ-337405	7-11	ET-348830	1-TR5A		
EC-344155	1-C1B	EJ-337406	7-9	ET-348831	1-TR7A		
EC-344478	3-C3A	EJ-342935	6-J1	ET-348832	1-TR11A		
EC-345607	3-C4A	EJ-348846	1-J13D	ET-348834	1-TR3A		
EC-345608	3-C5A	EL-348852	7-16	ET-348835	1-TR2A		
EC-345609	3-C6A	EL-348854	7-17	ET-348844	1-TR1B		
EC-345627	1-C16A	EO-332116	1-L1A	EV-337308	1-VR2B		
EC-345627	1-C17A	EO-336934	3-L4B	EV-338118	3-VR1A		
EC-345655	1-C2B	EO-336934	3-L3A	EV-361800	1-VR6A		
EC-345655	3-C7A	EO-336934	3-L2A	EW-305691	7-12A		
EC-345655	3-C10A	EO-336934	3-L2B	EW-336924	7-12S		
EC-345655	3-C12A	EO-336934	3-L3B	EW-343363	7-12C		
EC-345655	3-C11A	EO-336934	3-L1B	EW-346249	7-12B		
EC-345655	3-C9A	EO-337684	3-L1A	EW-346251	7-12E		
EC-345656	1-C1A	EO-342936	1-FL1D	EW-374894	7-12U		
EC-345656	1-C4A	EO-342936	6-FL1	EZ-631945	7-13		
EC-350675	3-C2A	EQ-348789	1-RL1A	SA-312465	7-20		
EC-350675	3-C14A	ER-306127	2-R22	SK-B348747A	8-20		
EC-350745	3-C1A	ER-306127	2-R23	SK-B348747B	8-20P		
ED-301911	1-D3A	ER-316802	2-R24	SK-B348748A	8-22		
ED-301911	1-D4A	ER-318248	2-FR3	SK-B348748B	8-22P		
ED-301911	1-D5A	ER-318248	2-FR4	SK-B348748C	8-24		
ED-301911	1-D13A	ER-319455	1-FR4A	SK-B348748D	8-24P		
ED-301911	1-D14A	ER-319455	1-FR5A	SK-B348749C	8-28		
ED-301911	2-D9	ER-319455	2-FR2	SK-B348749D	8-28P		
ED-301911	2-D10	ER-319455	2-FR1	SK-B348749E	8-26		
ED-301911	3-D2A	ER-324480	1-R60A	SK-B348749F	8-26P		
ED-301911	3-D1A	ER-327198	3-R23A	SK-B348752A	8-8		
ED-323535	1-D11A	ER-327198	3-R24A	SK-B348752B	8-8P		
ED-323535	1-D12A	ER-328068	1-R22A	SK-B348752C	8-10		
ED-324194	1-D10A	ER-333429	1-R25A	SK-B348752D	8-10P		
ED-330219	1-D1A	ER-337754	1-R50A	SK-B348754	8-6		
ED-330219	1-D2A	ER-337754	1-R49A	SK 342820A	8-14		
ED-337153	1-D9A	ER-337755	1-R59A	SK-342820B	8-14P		
ED-337153	1-D6A	ER-337756	1-FR6A	SK-348750C	8-12		
ED-337153	1-D7A	ER-337773	1-R13A	SK-348750D	8-12P		
ED-337391	1-D1F	ER-337773	1-R14A	SK-348751	8-33		
ED-337391	1-D2F	ER-338000	3-FR2A	SK-348756B	8-34P		
ED-345555	2-D13	ER-338000	3-FR1A	SK-348756C	8-34		
ED-345615	2-D11	ER-338078	3-R14A	SK-348757A	8-16		
ED-346564	2-D1	ER-338325	3-R13A	SK-348757B	8-16P		
ED-346564	2-D2	ER-345616	1-R48A	SK-348757C	8-18		
ED-346564	3-D3A	ER-345618	1-FR1A	SK-348757D	8-18P		
ED-346564	3-D4A	ER-345618	1-FR2A	SK-348762A	8-4		
ED-346575	2-D3	ER-345619	1-FR3A	SK-348762B	8-4P		
ED-346575	2-D5	ER-345664	3-R12A	SP-345583A	7-6U		
ED-346576	2-D4	ER-345751	1-FR8A	SP-345583B	7-6C		
ED-346576	2-D7	ER-345751	1-FR7A	SP-345583C	7-6E		
ED-346576	2-D8	ER-346864	3-R11A	SP-345583D	7-6B		
ED-346576	2-D6	ER-624756	1-R1D	SP-345587A	8-32		
ED-348786	2-D12	ES-337388	3-SW1A	SP-345587B	8-32P		
ED-348836	1-D8A	ES-343364	7-14	SP-345589A	8-35		
ED-348860	1-D1H	ES-343688	4-SW1U	SP-345589B	8-35P		
ED-348860	1-D2H	ES-343688	5-SW1	SP-348741A	8-5		
ED-348860	1-D3H	ES-345481	1-SW4B	SP-348759	8-2		
ED-348860	1-D4H	ES-345652	3-SW2A	SZ-348765	8-3x		
ED-348860	1-D5H	ES-348841	1-SW6B	ZG-322579	8-9x		
ED-348860	1-D7H	ES-348841	1-SW7B	ZG-322579	8-15x		
ED-348860	1-D8H	ES-348841	1-SW5B	ZG-322579	8-29x		
ED-348860	1-D6H	ES-348845	1-SW8C	ZG-322579	8-27x		
ED-348861	1-D1G	ES-348847	1-SW1E	ZG-322579	8-11x		
EF-310229	2-F3C	ES-348858	7-18	ZG-322579	8-13x		

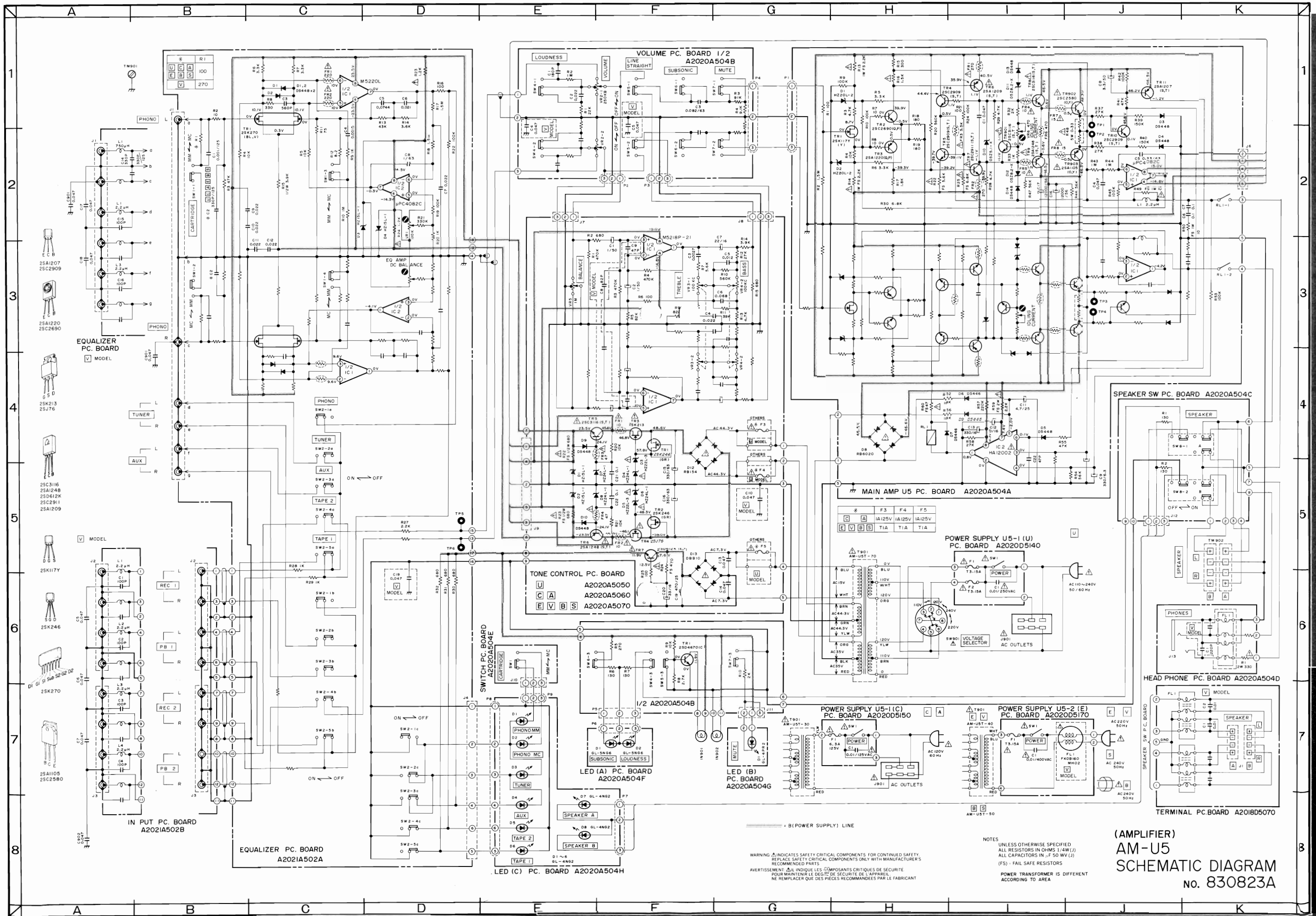

WARNING: INDICATES SAFETY CRITICAL COMPONENTS FOR CONTINUED SAFETY. REPLACE SAFETY CRITICAL COMPONENTS ONLY WITH MANUFACTURER'S RECOMMENDED PARTS.
 AVERTISSEMENT: Δ INDIQUE LES COMPOSANTS CRITIQUES DE SÉCURITÉ. POUR MAINTENIR LE DÉGRÉ DE SÉCURITÉ DE L'APPAREIL, NE REMPLACER QUE DES PIÈCES RECOMMANDÉES PAR LE FABRICANT.

NOTES
 UNLESS OTHERWISE SPECIFIED ALL RESISTORS IN OHMS 1/4W (J)
 ALL CAPACITORS IN .1F 50 WV (J)
 (FS) - FAIL SAFE RESISTORS
 POWER TRANSFORMER IS DIFFERENT ACCORDING TO AREA

(AMPLIFIER)
 AM-U5
 SCHEMATIC DIAGRAM
 No. 830823A

HA12002

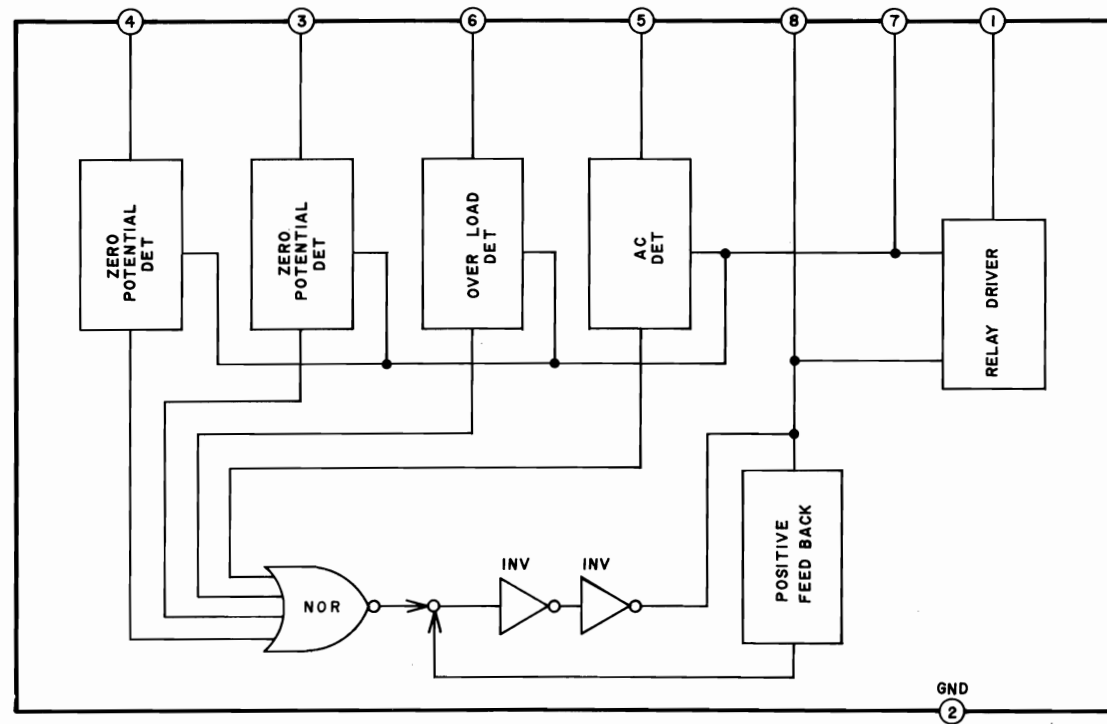

M5220L

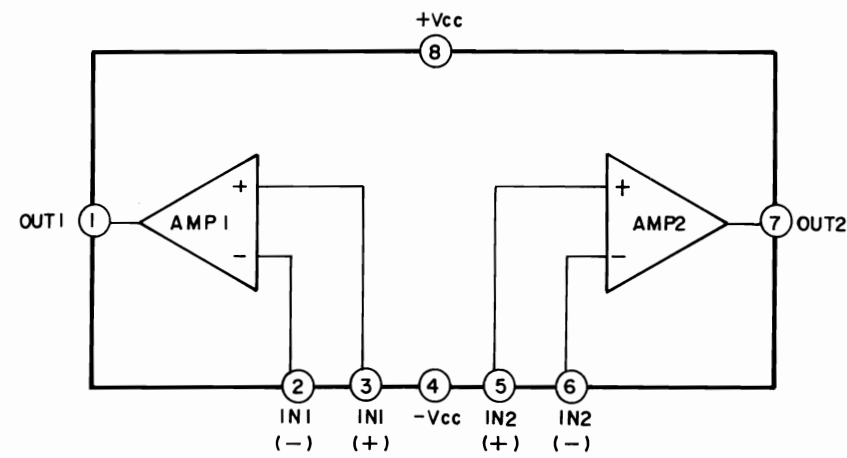

M5218P-21

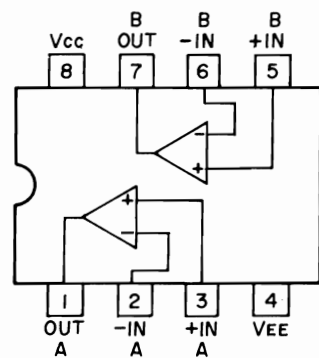

μ PC4082C

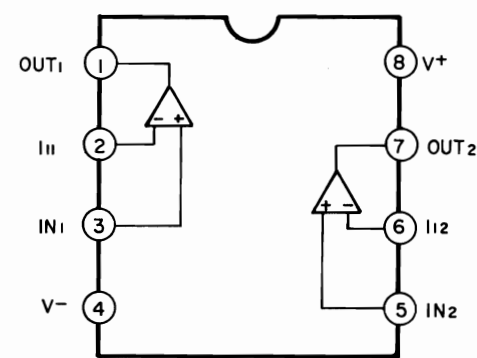

SECTION 3

SCHEMATIC DIAGRAM

TABLE OF CONTENTS

1. SCHEMATIC DIAGRAM	26
2. SCHEMATIC DIAGRAM OF ICs	27